

Project Data			
Customer Company		Offer Number	
Project Name		Offer Date	
Unit Project Code			

**Product Specifications**

**FHR16**



FHR Counter Flow Heat Recovery Units are used in restaurants, shops, historical buildings, offices and other places where clean air is needed. In places where air-conditioning is carried out by heating or cooling, low-quality air-conditioned indoor air is formed, where the internal carbon dioxide and other harmful gases are intense. By-pass damper provides free-cooling and anti-freeze protection of the heat exchanger. FHR Counter Flow Heat Recovery Devices operate on silent and high efficiency with plug fan motors. On the supply side there is a panel filter or an optional high-efficiency filter. With the control card sent as standard, the device can be operated at the desired flow rate.

- Counter Flow Heat Exchanger
- Low Sound Level
- EC Plug Fans
- By-Pass Damper (0-100%)
- M5+F7 Filters for Supply Side
- M5 Filter for Exhaust Side
- Plug&Play
- Optional Electric Heater
- Optional Heating/Cooling Coils
- Optional Sound Attenuator

Product Model	FHR16
Product Type	Commercial Type Heat Recovery
Heat Recovery Type	Aluminum Counterflow
Unit Casing	Double wall - Inside: 0.8 mm galvanized sheet
Unit isolation	50 mm 70 kg/m <sup>3</sup> -Rockwool
Casing Air Leakage	0
Unit Frame	-
Service Direction	Right
Voltage / Frequency / Phase (V / Hz / Ph)	230/50/1
Operating conditions	-20 ~ 46 ° C Temperature, 90% Max.RH Outdoor Air
Standard Air Density (kg/m <sup>3</sup> )	1.2

## Dimensions

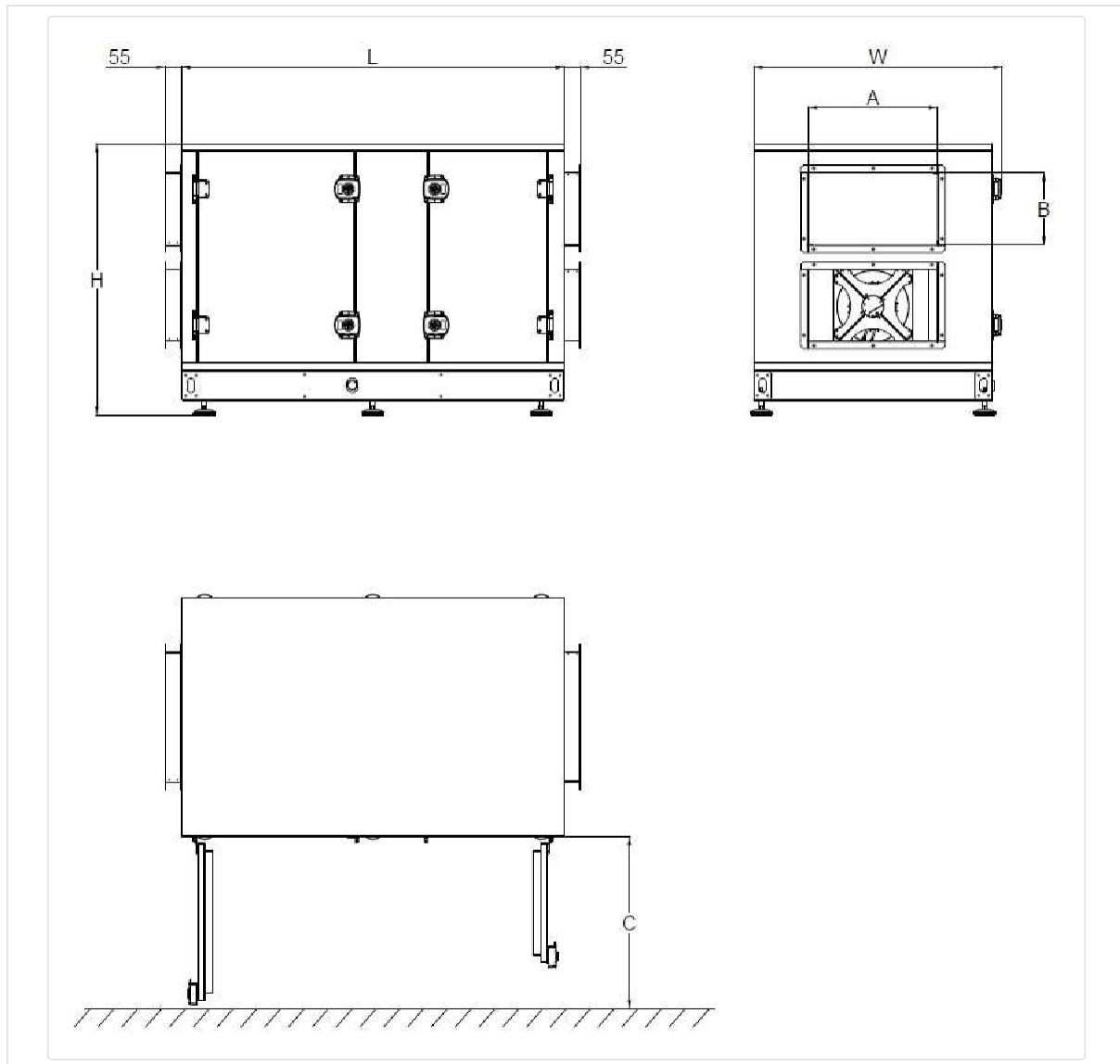

L	W	H	A	B	C
1555	865	945	550	300	750

## Performance Data

Supply Air Flow	m <sup>3</sup> /h	1250	Heat Recovery Efficiency	%	78.12
External Static Pressure	Pa	250	Heat Recovery Capacity	kW	10.17
Return Air Flow	m <sup>3</sup> /h	1250	Additional Heating Capacity	kW	0
External Static Pressure	Pa	250	Additional Cooling Capacity	kW	
Unit Total Power / Current	kW/A	0.8/3.46	Air Outlet Temperature	°C	15.18
SFP <sub>int,total</sub>	W/m <sup>3</sup> /s	1356.91	Energy Efficiency Class	-	

## Heat Recovery Data

Heat Recovery Type	Aluminum Counterflow --
Fin Pitch (mm)	0

Winter		Outside Air	Return Air
Air Inlet Flow	m <sup>3</sup> /h	1250	1250
Air Inlet Temperature (DB / WB)	°C	-10 / -10.32	21 / 12.66
Air Inlet Relative Humidity	%	90	37
Air Outlet Temperature (DB / WB)	°C	15.18 / 5.19	1.78 / 0.38
Air Outlet Relative Humidity	%	13.58	77.27
Heat Recovery Pressure Drop	Pa	215.20	277.65
Heat Recovery Efficiency (Dry / Wet)	%	78.12 / 81.22	-
Heat Recovery Capacity (Dry / Wet)	kW	10.17 / 10.58	-10.17 / -10.58
Condensation	kg/h	0.00	3.56

Summer		Outside Air	Return Air
Air Inlet Flow	m <sup>3</sup> /h	1250	1250
Air Inlet Temperature (DB / WB)	°C	28 / 22.07	23 / 19.83
Air Inlet Relative Humidity	%	60	75
Air Outlet Temperature (DB / WB)	°C	24.13 / 20.94	26.87 / 21.02
Air Outlet Relative Humidity	%	75.42	59.53
Heat Recovery Pressure Drop	Pa	262.71	256.40
Heat Recovery Efficiency (Dry / Wet)	%	77.3904 / 77.39	-
Heat Recovery Capacity (Dry / Wet)	kW	-1.64 / -1.64	1.64 / 1.64
Condensation	kg/h	0.00	0.00

## Filter Data

		SA Filter 1	SA Filter 2	EA Filter	EA Filtre 2
Filter Class	-	M5	F7	M5	
Filter Class (ISO 16890)	-	ISO ePM10 50%	ISO ePM1 50%	ISO ePM10 50%	
Filter Initial Pressure Drop	Pa	71.57	91.57	71.57	
Filter Final Pressure Drop	Pa	170	200	170	
Filter Average Pressure Drop	Pa	120.785	145.785	120.785	
Filter Surface Air Velocity	m/s	2.0436	2.0436	2.0436	2.0436

## Fan Data

		Outside Air	Return Air
Air Flow	m <sup>3</sup> /h	1250	1250
Fan Speed	d/d	3403.5	3312.93
Nominal Fan Speed	d/d	3740	3740
Fan Power	Watt	404.99	390.01
Operating Point Current	A	1.76	1.7
Voltage / Frequency / Phase	V/Hz/Ph	230 / 50 / 1	230 / 50 / 1

Fan LWA			LWA (In+Out)	LWA	63Hz	125Hz	250Hz	500Hz	1kHz	2kHz	4kHz	8kHz
Supply Fan	Inlet	dBA	82,00	75,25	67,20	69,20	70,50	70,10	70,50	68,70	65,70	61,90
	Outlet	dBA		80,80	75,40	76,80	76,90	75,60	76,00	74,20	71,20	67,30
Return Fan	Inlet	dBA	81,45	75,25	67,20	69,20	70,50	70,10	70,50	68,70	65,70	61,90
	Outlet	dBA		80,80	75,40	76,80	76,90	75,60	76,00	74,20	71,20	67,30

Fan LPA	@ 1 m		LPA (In+Out)	LPA	63Hz	125Hz	250Hz	500Hz	1kHz	2kHz	4kHz	8kHz
Supply Fan	Inlet	dBA	74.02	67.27	59.22	61.22	62.52	62.12	62.52	60.72	57.72	53.92
	Outlet	dBA		72.82	67.42	68.82	68.92	67.62	68.02	66.22	63.22	59.32
Return Fan	Inlet	dBA	74.02	67.27	59.22	61.22	62.52	62.12	62.52	60.72	57.72	53.92
	Outlet	dBA		72.82	67.42	68.82	68.92	67.62	68.02	66.22	63.22	59.32