

Note!

There are two options for time schedule operation. For details, follow manual for uPC3



EN

Operation and Maintenance Manual

VENTUS Suspended Air-Handling Units
Rated air flow range 280 – 4300 m³/h

VENTUS

Table of content

| | | |
|-------|---|----|
| 1 | Warming, Cautions and Notices..... | 4 |
| 2 | Model Descriptions | 5 |
| 3 | General Information | 6 |
| 4 | Pre-Installation..... | 9 |
| 4.1 | Transport and storage | 9 |
| 4.1.1 | Receiving Checklist..... | 9 |
| 4.2 | Installation Preparation..... | 10 |
| 4.2.1 | Unit Location Recommendations..... | 10 |
| 4.2.2 | Assembly in suspended position | 10 |
| 4.2.3 | Setting in vertical position..... | 15 |
| 4.2.4 | Connecting the ventilation ducts | 15 |
| 4.2.5 | Connection of heaters and coolers | 16 |
| 4.2.6 | Draining out condensate | 18 |
| 4.2.7 | Electric connection | 19 |
| 4.3 | Service Access | 19 |
| 4.3.1 | Skid Removal | 20 |
| 4.4 | AHU components | 20 |
| 4.4.1 | Hydronic coil exchangers..... | 20 |
| 4.4.2 | DX Coils..... | 20 |
| 4.4.3 | Electric Heaters | 22 |
| 4.4.4 | Fan's motors | 27 |
| 4.4.5 | Air Filters | 28 |
| 5 | Automation..... | 29 |
| 5.1 | Description of controls | 29 |
| 5.1.1 | Introduction | 29 |
| 5.1.2 | Mains switch | 29 |
| 5.1.3 | Communication port..... | 29 |
| 5.1.4 | Signaling controller status..... | 29 |
| 5.1.5 | Simplified control panel – HMI Basic UPC..... | 30 |
| 5.2 | System Start-Up | 31 |
| 5.2.1 | Switching on power supply | 31 |
| 5.2.2 | HMI Advanced UPC | 32 |
| 5.2.3 | Selection of operating mode..... | 32 |
| 5.2.4 | Indication of operating mode | 33 |
| 5.3 | Technical data..... | 33 |

| | | |
|-------|---|----|
| 5.3.1 | Operation parameters | 33 |
| 5.3.2 | Carel µPC controller..... | 34 |
| 5.3.3 | Cabling | 35 |
| 5.4 | Connection..... | 37 |
| 5.4.1 | Standard connection | 37 |
| 5.4.2 | Power connection | 37 |
| 5.4.3 | Connection of automation elements..... | 37 |
| 6 | Preparation for start-up..... | 41 |
| 6.1 | Electrical system..... | 41 |
| 6.2 | Filters..... | 41 |
| 6.3 | Water heaters | 41 |
| 6.4 | Electric heaters | 42 |
| 6.5 | Water and freon coolers..... | 42 |
| 6.6 | Counter-flow heat exchangers | 42 |
| 6.7 | Fan unit..... | 42 |
| 7 | Start-up and adjustment..... | 43 |
| 7.1 | Measurement of air quantity and AHU output adjustment..... | 43 |
| 7.2 | Heat output adjustment of water heater..... | 44 |
| 7.3 | Adjustment of electric heater..... | 44 |
| 7.4 | Adjustment of cooler performance | 44 |
| 8 | Operation and maintenance..... | 45 |
| 8.1 | Dampers..... | 45 |
| 8.2 | Filters..... | 45 |
| 8.3 | Heat exchangers..... | 46 |
| 8.3.1 | Water heater | 46 |
| 8.3.2 | Electric Heater..... | 46 |
| 8.3.3 | Water cooler | 47 |
| 8.3.4 | Freon cooler and heater | 47 |
| 8.3.5 | Counter flow heat exchanger..... | 47 |
| 8.4 | Silencer section..... | 48 |
| 8.5 | Fan unit..... | 48 |
| 9 | Safety instructions | 49 |
| 10 | Information..... | 49 |
| 11 | Technical information to the regulation (U) No 327/2011 | 50 |

In–depth familiarization with the content of this manual, assembly, start–up and operation of the air handling unit in line with the instructions provided and following all safety regulations will ensure the basis of efficient, safe and non–failure operation of the device.

This operation and maintenance manual does not cover all possible variants of the unit's configurations, examples of their assembly and installation as well as start–up, operating, repairing and maintenance. If the units are used for what they are intended, this documentation and any other materials provided with the unit contain information designed for the qualified technical personnel only.

1 Warming, Cautions and Notices



SAFETY WARNING!

- The installation, starting up, and servicing air handling units and their equipment can be hazardous and requires specific knowledge and training.
- Improperly installed, adjusted or altered equipment by an unqualified person could result in death or serious injury.
- When working on the equipment, observe all precautions in the literature and on the tags, stickers, and labels that are attached to the equipment.
- Installation, maintenance and repair must be carried out by qualified technical personnel or they are supervised by authorized staff.

The **qualified technical personnel** is understood as the trained specialists, who due to the professional experience, knowledge of the subject–related standards, documentation and regulations concerning operation and safety procedures, have been authorized to perform necessary operations and who are able to troubleshoot any potential problems.

- Warranty repairs of VTS AHUs can only be performed by Authorized VTS Service, having an appropriate certificate allowing this type of works. We also recommend that Authorized VTS Service should carry out assemblies, start–ups, post–warranty repairs, overhauls and maintenance works performed on AHUs.

ATTENTION: Warnings, Cautions and Notices appear throughout this document. Read it carefully:



WARNING!

Indicates a potentially hazardous situation which, if not avoided, could result in death or serious injury.



CAUTION!

Indicates a potentially hazardous situation which, if not avoided, could result in minor or moderate injury. It could also be used to alert against unsafe practices.



NOTICE !

Indicates a situation that could result in equipment or property–damage only.

Failure to follow recommendations could result in death or serious injury.







2 Model Descriptions

The VENTUS suspended air handling units are draw-through air handlers for recuperation, cooling or/and heating load conditions of the air flow range 280–4300 m³/h. The VENTUS air-handling units are designed for a ventilation system where an access to the rotating parts of the unit (a fan's rotor) is feasible neither from the overpressure nor sub atmospheric pressure side of the unit.

AHUs are equipped with a wide range of functional sections which offers extensive possibilities of realizing the air treatment process starting from the simplest supply and exhaust to conditioning the supplied air in the field of such parameters as temperature (heat recovery, heating: water or electric heaters, cooling: water or freon coolers), filtration, primary and secondary filters as well as noise level reduction (we offer silencing curtains without any casing to be assembled inside a duct).

There is a list of symbols and functions of air handling units:

Table 1 Functions coding

| Symbol | Graphic | Function | Options of functions |
|--------|---|--|------------------------------|
| F |  | Air filtration | M5,F7, F9 |
| V |  | Ventilation | |
| C |  | Cooling (hydronic or dx) | Rows: 2, 4, 6 |
| H |  | Heating (hydronic) | Hot Water – rows: 1, 2, 3, 4 |
| |  | Heating (electric) | Draw-through electric heater |
| S |  | Silencer | Standard size |
| P |  | Recovery with counter-flow heat exchangers | Standard size |

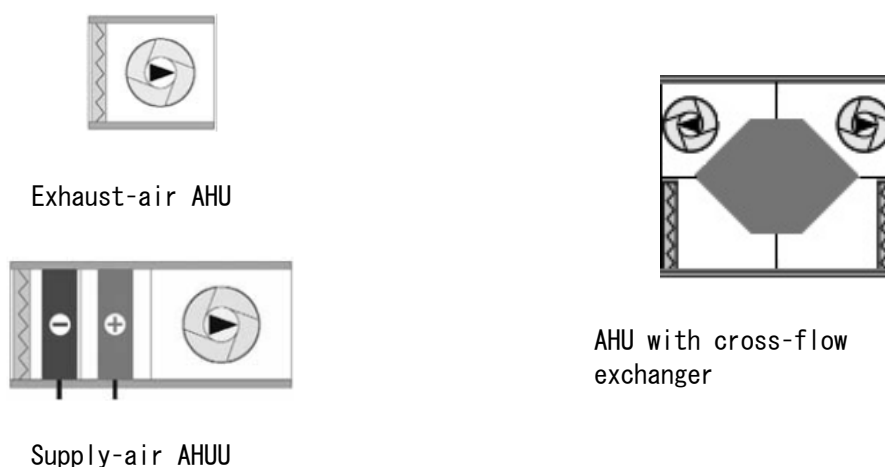

Fig.1. Examples of suspended AHUs type VVS010s –015s functional configurations

3 General Information

VVS suspended units are manufactured in sections designed for assembly in suspended configurations. All VVS AHUs are intended for indoor use, for cooperation with a duct ventilation system. The ventilation duct system is understood as a net of ventilating ducts. Thus access to the rotating parts of the unit (a fan's rotor) is impeded from both positive and negative pressure side of the unit.

The majority of AHU's configuration is available in left-hand and right-hand execution (example in the fig.2). The version of the unit is determined by the flow direction of the air against the piping side of the unit (the side where the coils connection pipes are located). In case of supply-exhaust units the version is determined by the flow direction of the air in the supply section.

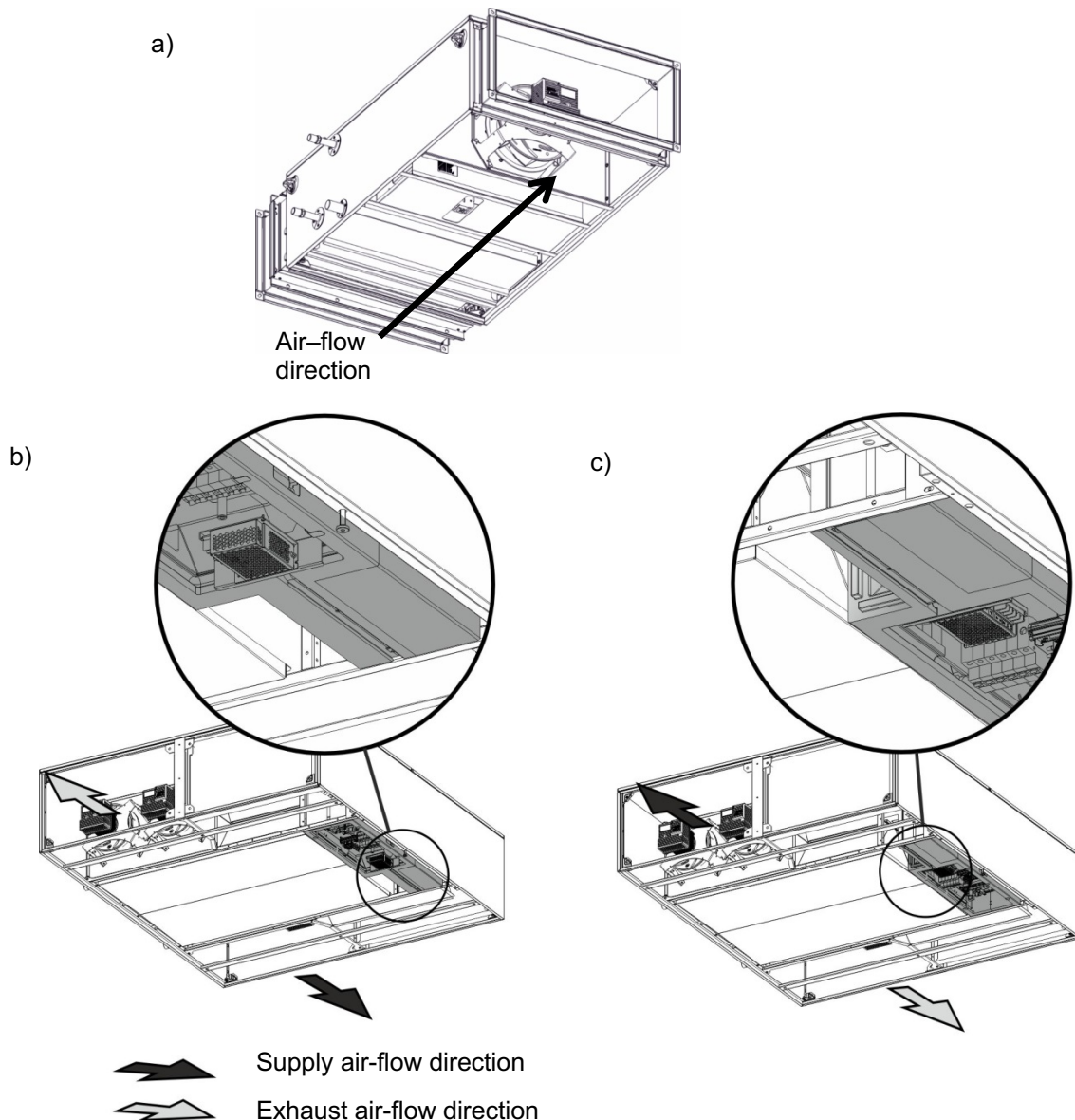

Fig. 2 Versions of the VVS005s–030s AHU: a) Supply unit: Right-hand version, b) Basic supply-exhaust unit (FPV) – Left-hand version, c) Basic supply-exhaust unit (FPV) – Right-hand version

By default the VVS05s–030s AHU is positioned horizontal-suspended. In case of some

functional set it is also possible to set the unit in a vertical position – on a wall.

Basic heat recovery unit components consist of a counter flow heat exchanger, condensate FPV + HC:

drain pan, filters, direct drive fan assemblies (fig.3).

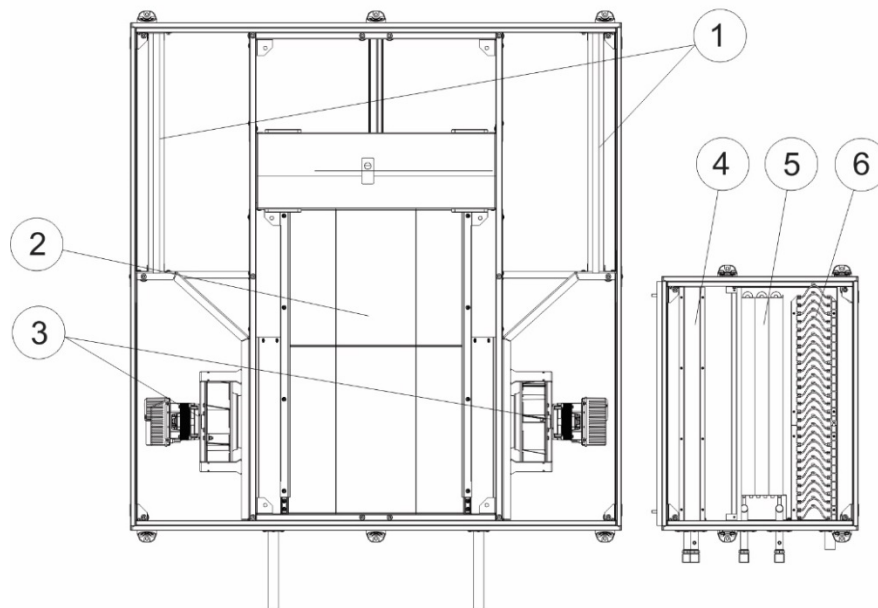

Fig.3. Example of the basic supply–exhaust unit (FPV) with additional coils section (HC):
1 – filters, 2 – counter–flow heat exchanger, 3 – fans, 4 – heater, 5 – cooler, 6 – droplet eliminator

VVS005s–030s AHUs consist of freely configurable sections. One can find recovery section with very high efficiency counter–flow plate heat exchanger, filters (M5 and F7) and fans with EC motors. For that main unit is possible to choose additional section with

heater (water and electric, cooler (water and Freon), secondary filter and silencer. The functions like filtration, heating and cooling are also available installed in one section with a fan (tab.2, fig.4).

Table 2 Functionality and length of the sections

| Function | Name | VVS 005s | VVS 010s | VVS 015s | VVS 020s | VVS 030s |
|----------|---|----------|-----------|----------|----------|----------|
| | | L [mm] | | | | |
| F | Filter | 180 | | | | |
| H | Water heater | 180 | | | | |
| HE | Electric heater | 370 | | | | |
| C | Cooler (water or freon) | 370 | | | | |
| C_de | Cooler with droplet eliminator | 460 | | | | |
| HC | Water heater and cooler | 460 | | | | |
| HC_de | Water heater and cooler with droplet eliminator | 600 | | | | |
| HEC | Electric heater and cooler | 740 | | | | |
| HEC_de | Electric heater and cooler with droplet eliminator | 860 | | | | |
| FPV | Plate heat exchanger, filters and fans | 1230 | 1500 | | 1828 | |
| V | Fan | 370 | 460 | | | |
| FV | Filter and fan | 460 | 740 | | | |
| FHV | Filter, water heater and fan | 460 | 740 | | | |
| FHEV | Filter, electric heater and fan | 740 | 1030 | 1030 | 1100 | |
| FCV | Filter, cooler and fan | 740 | 860/1030* | | 1110 | |
| FCV_de | Filter, cooler with droplet eliminator and fan | 860 | 1030 | | 1110 | |
| FHCV | Filter, water heater, cooler and fan | 860 | 1030 | | 1100 | |
| FHCV_de | Filter, water heater, cooler with droplet eliminator and fan | 1030 | 1230 | | | |
| FHECV | Filter, electric heater, cooler and fan | 1030 | 1230 | | 1380 | |
| FHECV_de | Filter, electric heater, cooler with droplet eliminator and fan | 1230 | 1380 | | 1450 | |
| S | Silencer L=370 | 370 | | | | |
| S | Silencer L=740 | 740 | | | | |

| | | |
|---|---------------------|-----|
| E | Empty section L=370 | 370 |
| E | Empty section L=740 | 740 |

*for section with cooling coils bigger than 4 rows

HC:

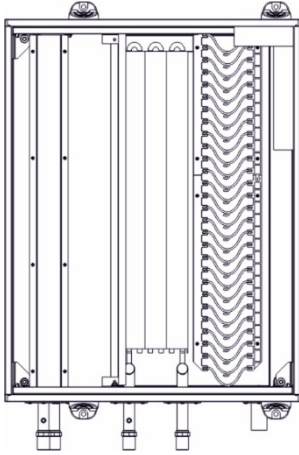

FHEV:

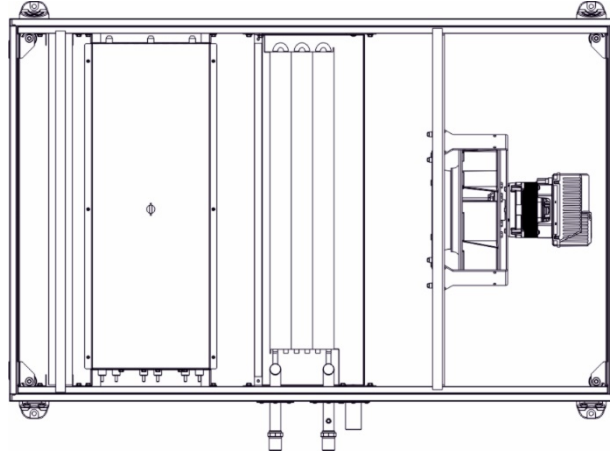

Fig.4. Example of the sections

| AHU size | W [mm] | H [mm] |
|----------|--------|--------|
| VVS005s | 375 | 380 |
| VVS010s | 575 | 380 |
| VVS015s | 775 | 380 |
| VVS020s | 775 | 470 |
| VVS030s | 1080 | 470 |

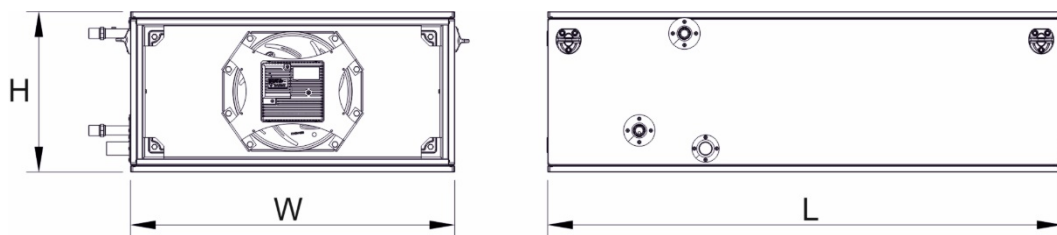

Fig.5. Dimension of the section

4 Pre-Installation

4.1 Transport and storage

The air handling units are packaged for easy handling and storage on the job site. Upon delivery, inspect all components for possible shipping damage. See the “Receiving Checklist” section for detailed instructions. VTS recommends leaving units and accessories in their shipping packages/skids for protection and handling ease until installation.

- ☑ **NOTICE!** Packages onsite must be stored on hardened, dry and protected against any precipitation place.
- ☑ Packages containing AHU elements should be stored away from places where operate mechanical devices (vehicles, cranes and other construction machinery). They should be stored in places where they will not be subject to any mechanical damages, humidity, aggressive chemical agents, fluids, dusts and other external agents which may deteriorate their condition.

The AHUs have to be transported in their working position and they shall not be stored one on the other.

The units and their components should be stored in rooms characterized by the following conditions: relative humidity: $\phi < 80\%$ at t (temperature) = 20°C ambient temperature: $-40^{\circ}\text{C} < t < +60^{\circ}\text{C}$ – the devices should be out of the reach of any caustic dust, gas or steam as well as any other chemical substances which may have pro-corrosive influence on the unit and its components.

While storing the unit, its plastic packaging must be unsealed.

4.1.1 Receiving Checklist

Complete the following checklist immediately after receiving unit shipment to detect possible shipping damage.

- | | |
|---|--|
| <ul style="list-style-type: none"> <input type="checkbox"/> Inspect individual crates before accepting. Check for rattles, bent crates corners, or other visible indications of shipping damage. <input type="checkbox"/> If a unit appears damaged, inspect it immediately before accepting the shipment. Make specific notations concerning the damage on the freight bill. Do not refuse delivery. <input type="checkbox"/> Inspect the unit for concealed damage before it is stored and as soon as possible after delivery. Report concealed damage to the freight line within the allotted time after delivery. Check with the carrier for their allotted time to submit a claim. <input type="checkbox"/> Do not move damaged material from the receiving location. It is the receiver's responsibility to provide reasonable evidence that concealed damage did not occur after delivery. | <ul style="list-style-type: none"> <input type="checkbox"/> Do not continue unpacking the shipment if it appears damaged. Retain all internal packing, cartons, and crate. Take photos of damaged material if possible. <input type="checkbox"/> Notify the carrier's terminal of the damage immediately by phone and mail. Request an immediate joint inspection of the damage by the carrier and consignee. <input type="checkbox"/> Notify your VTS representative of the damage and arrange for repair. Have the carrier inspect the damage before making any repairs to the unit. <input type="checkbox"/> Compare the electrical data on the unit nameplate with the ordering and shipping information to verify the correct unit is received. |
|---|--|

☑ **NOTICE!**

Any damages caused by improper transportation, unloading or storage are not covered by the Warrantee and any claims laid by way of aforementioned issues will not be examined by VTS.

4.2 Installation Preparation

The units are designed for suspended installation. Suspension of units requires external rigging which shall be field-mounted. Ensure the ceiling opening is large enough for unit installation and maintenance requirements.

By default the AHU is positioned horizontal-suspended and also it is possible to set the unit in a vertical position – on a wall.

- ☑ **NOTICE!** It is not acceptable to install the units horizontally on a wall (sideways – in parallel to the ceiling). In case of vertical assembly it is important that the exchanger's inlet and outlet connections were positioned horizontally. Air flow must be directed vertically. Devices equipped with an electric heater cannot be mounted vertically.

4.2.1 Unit Location Recommendations

When selecting and preparing the unit installation location, consider the following recommendations.

1. Consider the unit weight. Reference the unit weight on the unit nameplate
2. Allow sufficient space for the recommended clearances, access panel removal, and maintenance access.
3. The installer must provide external rigging for ceiling mounted units.
4. All units must be installed level – only the recovery section with counter - flow heat exchanger must be installed with a 0.5% drop in the direction of the drain pipe (fig.6a)
5. Coil piping and condensate drain requirements must be considered.

Allow room for proper ductwork and electrical connections. Support all piping and ductwork independently of unit to prevent excess noise and vibration.

For the right connection of the duct inside the unit have been placed the stickers showing outlet and inlet to the room Fig.5a.

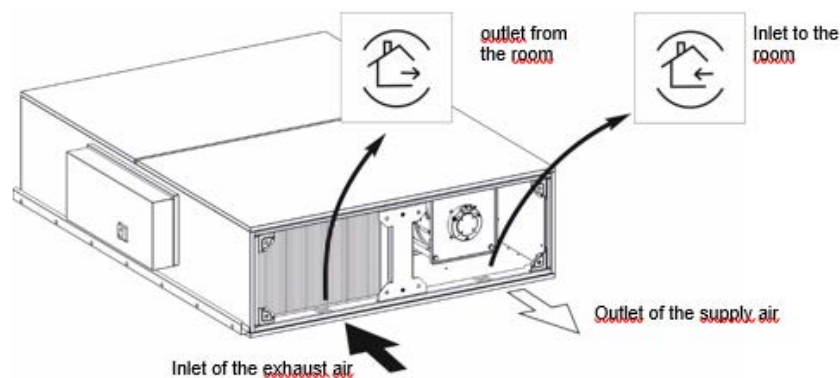

Fig 5a: Side connection to the room

4.2.2 Assembly in suspended position

Suspension of an AHU as a part of ventilation ducts is carried out using suspension grips which are located at a side of each AHU section (fig.8). Application of M8 screwed rods facilitates and speeds up suspension and

levelling of each AHU section (the screwed rods are not included).

- ☑ **NOTICE!** It is recommended to use vibro absorber to suspend the units, to reduce the vibrations transmitted to the supporting structure.

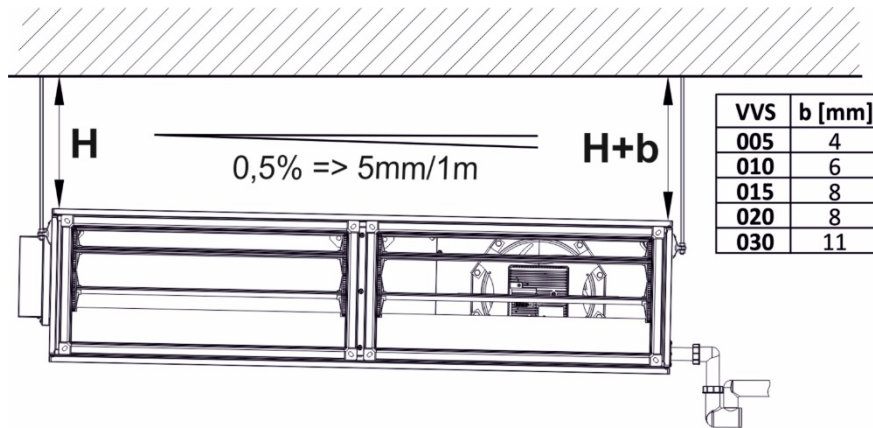

Fig.6a Levelling of the recovery section

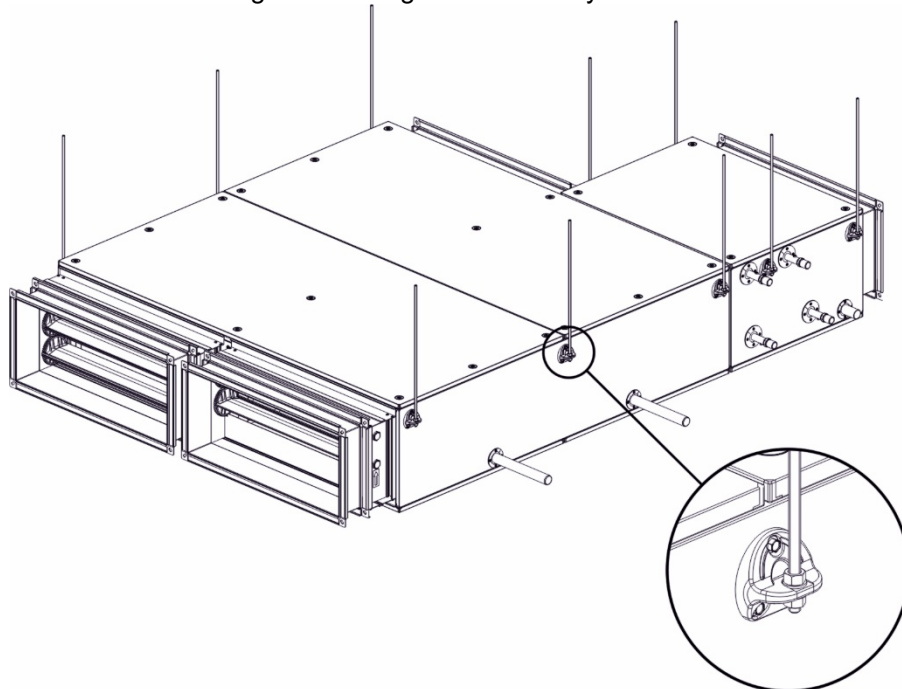

Fig.6b Example of suspending the AHU sections

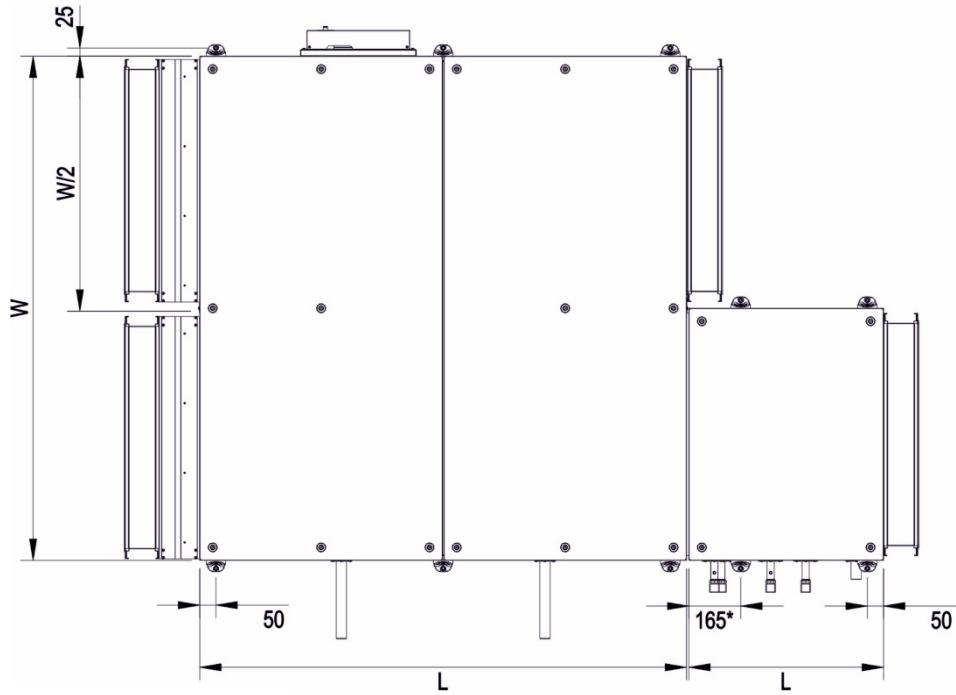

Fig.7 Suspension grips arrangement

| AHU size | W [mm] |
|----------|--------|
| VVS005s | 750 |
| VVS010s | 1150 |
| VVS015s | 1550 |
| VVS020s | 1550 |
| VVS030s | 2160 |

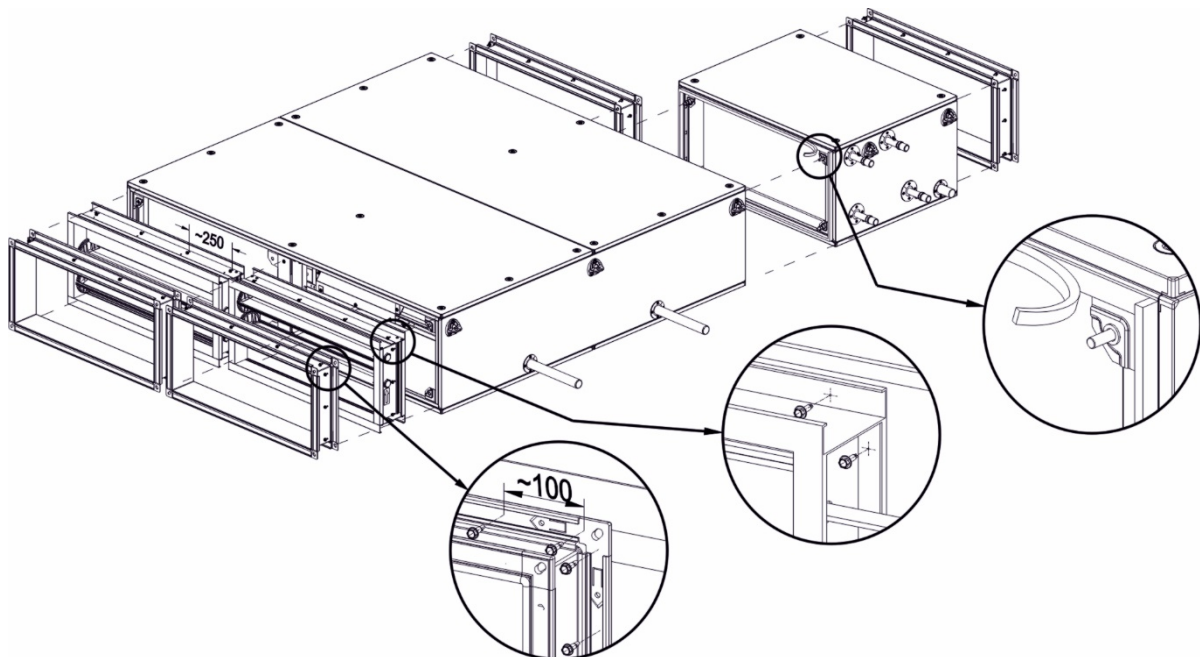

Fig.8a Joining sections and optional elements assembly.

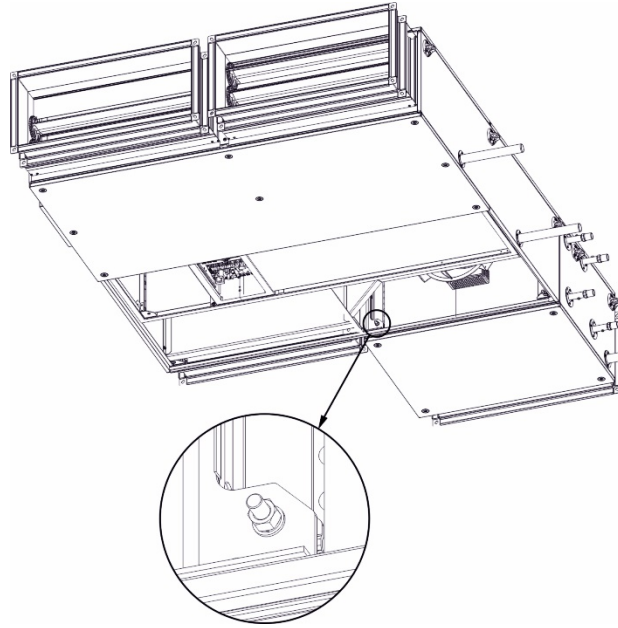

Fig.8b Joining sections and optional elements assembly.

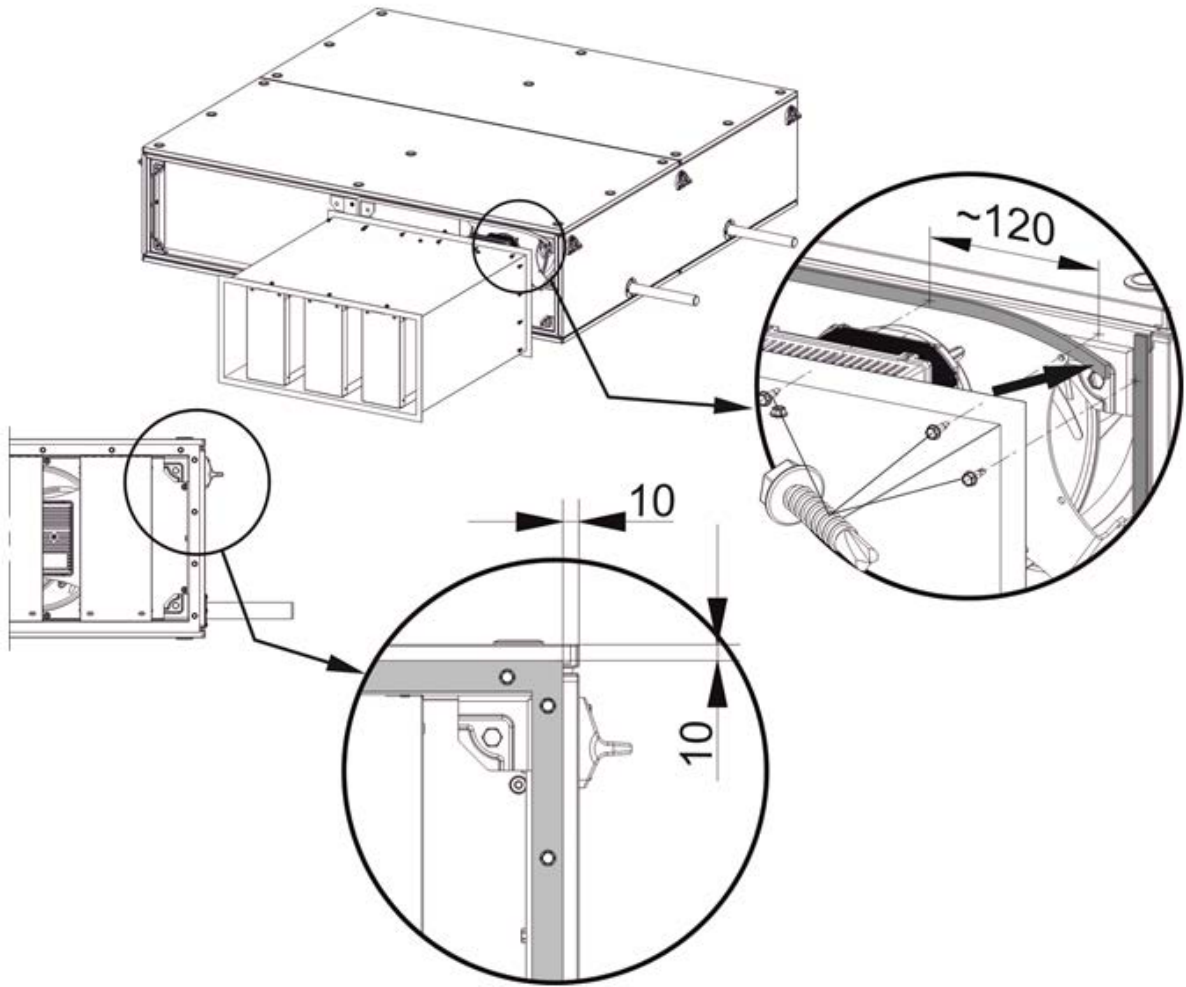

Fig.8c Joining silencer section to the base.

4.2.3 Setting in vertical position

- ☑ **NOTICE!** This position is not allowed for the AHUs containing the cooling or electric heating section as well as the cross-flow exchanger section.

Setting in this position requires a rigid framework fixed to a wall. The AHU should be mounted to the framework with fixing grips and M8 screws.

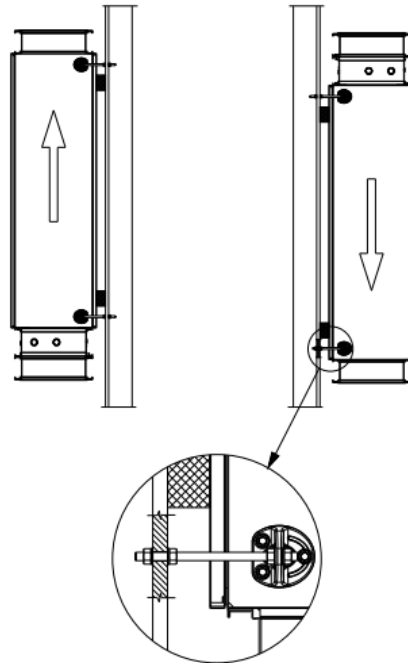

Fig.9 Example of setting AHU in vertical position

4.2.4 Connecting the ventilation ducts

The ventilation ducts should be connected to the AHU with the flexible connections (optional accessory) which suppress vibrations of the unit and level the coaxial deflection of the duct and the AHU outlets. Flexible connections are equipped with flanges with sealing. The flexible flanges should be connect with ducts with using drilling screws (Fig.10a) or additional clamping elements (Fig. 10b). Materials to connect ducts are not supplied as standard delivery.

Appropriate operation of the flexible connection occurs if it is stretched to about 110 mm.

The ducts connected to the AHU have to be suspended or underpinned with dedicated support elements.

Conducting the ducts with the fittings should be done in a way to eliminate possible increase of noise level in the ventilation system.

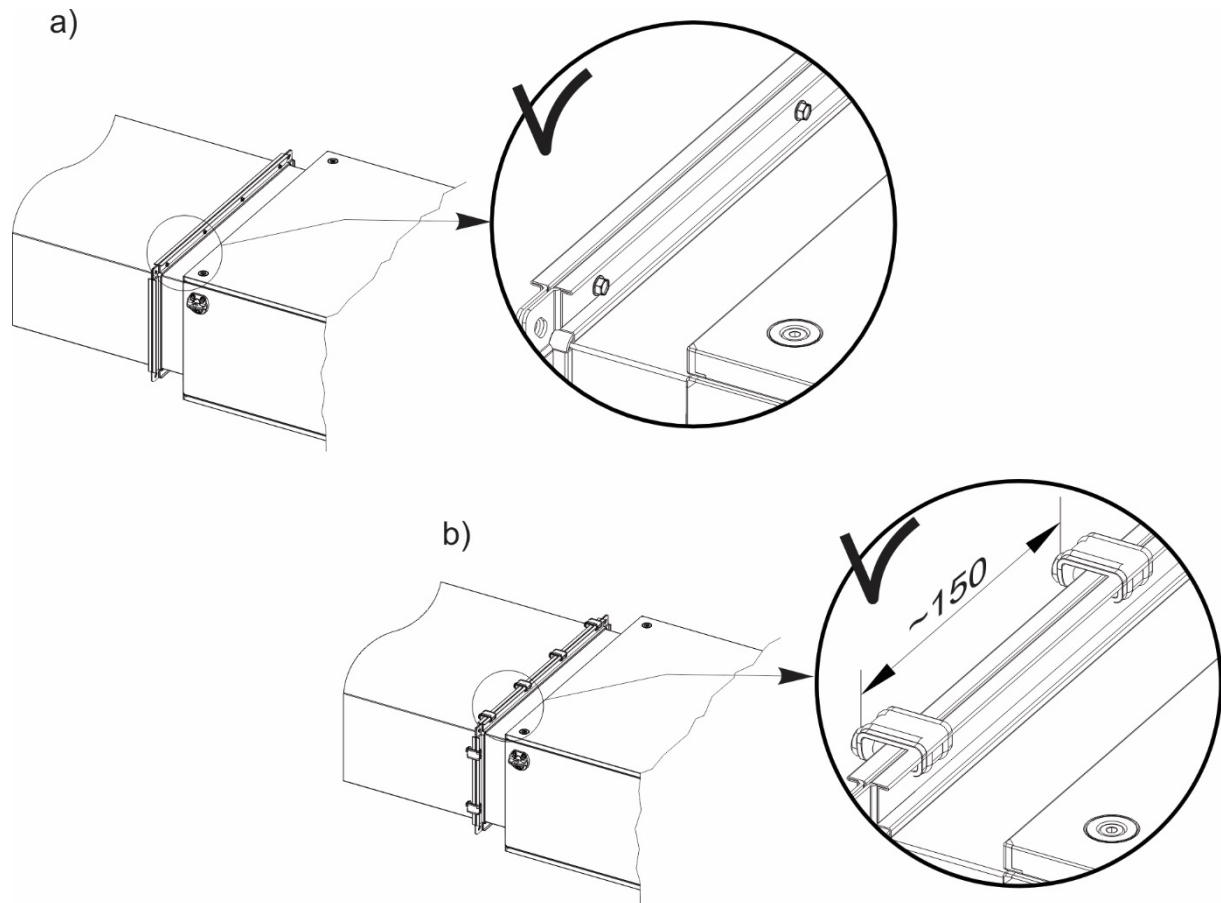

Fig.10 Duct's connection rules

4.2.5 Connection of heaters and coolers

Connection of the exchangers should be carried out so as not to allow for stresses which may result in mechanical damages or leakage. The pipeline weight and thermal stresses cannot be passed onto the exchanger's connections. Depending on a local conditions please use the compensation at the supply and return of the pipeline system, in order to level the pipeline's linear expansion. During assembly of the supply system to the exchangers equipped with the screwed connections, counter the exchanger's connection with additional wrench (fig.11).

The supply system should be planned so as it does not collide with the other AHU sections. Applied method of connecting the exchangers with the supply system should allow for an easy pipeline disassemble in order to remove the exchanger from the AHU, during maintenance and service operations.

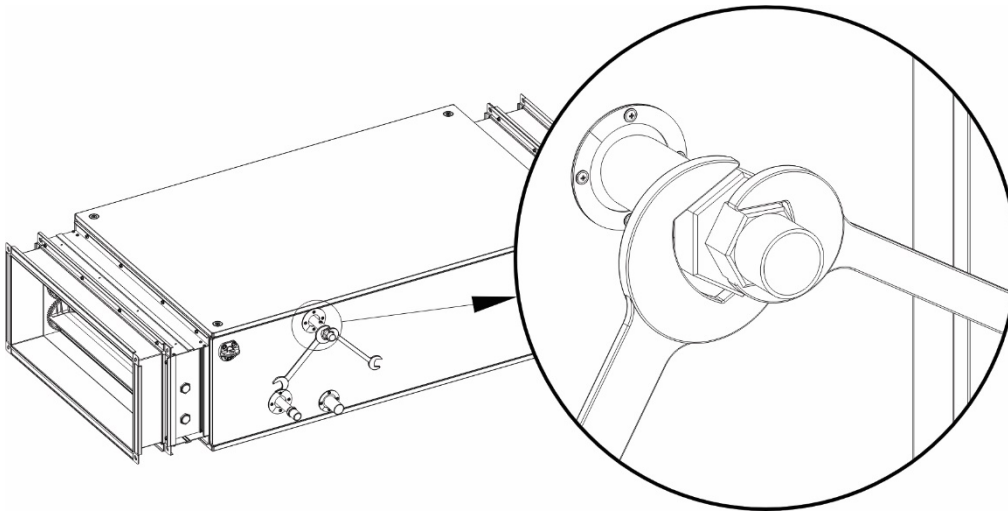

Fig.11. Securing the screwed connections of the exchanger

Supply and return exchanger connections should be connected so as the exchanger operates in a countercurrent way. Stream wise operation results in lower average temperature difference, influencing the exchanger's performance.

Examples of connecting supply and return pipelines for various AHU versions shown in the fig.12

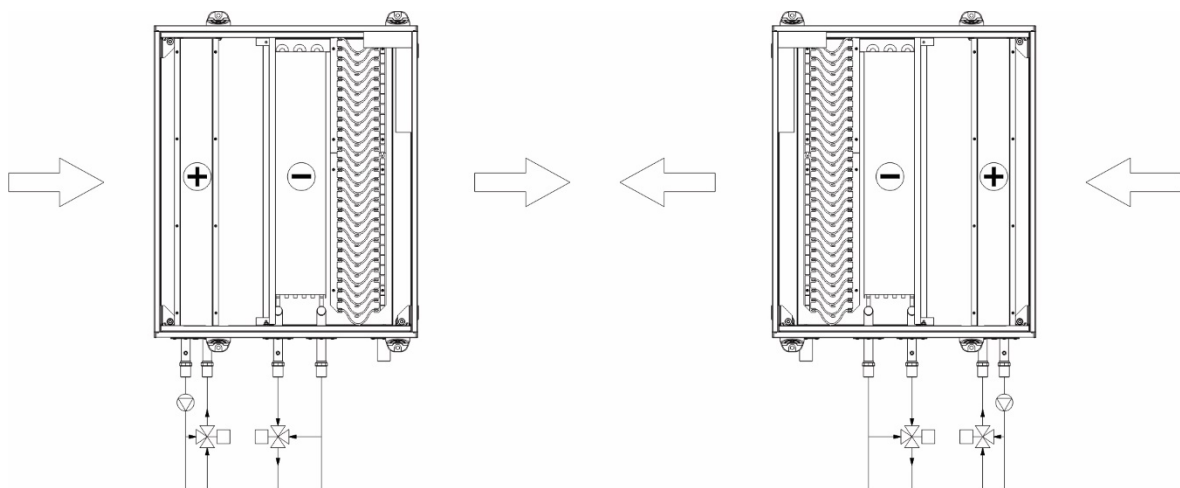

Fig.12. Examples of feeding water exchangers

Connecting the freon cooler to the supply system with a refrigerating unit should be done by a qualified cooling system specialist in accordance with the regulations concerning the freon-driven cooling devices.

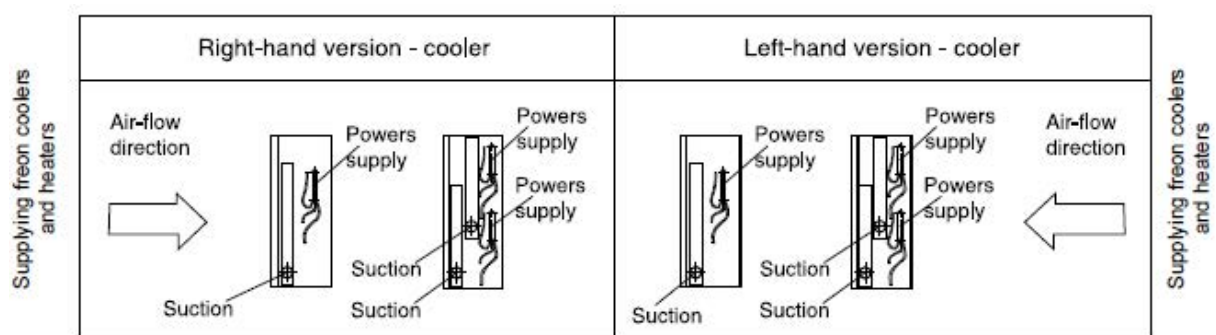

Fig. 13 Supplying freon coolers and heaters

- ✔ **NOTICE:** The DX coils have sweat connections. When brazing or welding piping: avoid exposing piping components to high heat when making sweat connections and protect the closest valve to the connection with a wet rag.
- ✔ **NOTICE:** Do not release refrigerant to the atmosphere! If adding or removing refrigerant is required, the service technician must comply with all federal, state, and local laws.
- ✔ **NOTICE:** Secure the coil against frost on the coil
- ✔ **NOTICE:** To ensure satisfactory operation of DX coolers the coolers should be connected to the refrigerant system in accordance with all relevant regulations, rules and the best practice for that area.

4.2.6 Draining out condensate

The outlet condensate connections, led outside the AHU's casing are assembled in the drain plates of coolers, counter-flow heat exchangers (the diameter of drain pan connection pipe is 32mm).

To avoid damage drain pipe of the counter-flow heat exchanger section during transportation, they are not installed and attached separately in the package.

To mount the drain pipe one should unscrew the drilling screws and disassembly header connection glands (magnification (1) in the the below figure), install the pipe on the drain pan connection inside the casing and assembly back the header glands (2).

Siphons, which are designed to drain out condensed water from the exchangers at different pressure of the section and environment, should be connected to the drain connections.

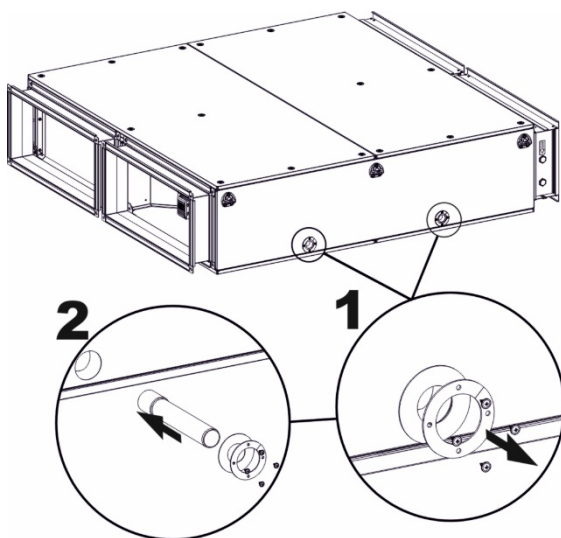

For proper drainage of condensate from the unit, the siphon on the drain pan connection pipe must be installed in the AHU sections, where negative pressure occurs. Drain siphons or siphon parts are not supplied as standard delivery. There is no need to apply drain siphons in section with overpressure. In order to minimize air blow-by, you can use a siphon on the system draining out condensate, assembling the siphon made in accordance with fig. 14 and table 3.

Siphons usable „H" height depends on the pressure difference between the AHU section, where condensate is drained from during operation and the ambient pressure. „H" dimension is provided in mm and must be higher than the pressure difference expressed in mmH₂O.

✔ **NOTICE!** Due to various pressure difference values which are present in various AHU sections during operation it is not allowable to connect several condensate outlets into one siphon.

It is allowable to join together siphons of various sections with one drain interceptor provided that the interceptor will be equipped with air-escape. Before starting the AHU, fill the siphon with water. In case of cold environment, insulate the water drain system and eventually apply suitable heating system.

Table 3. Siphons' operational height

| No. | Total fan's pressure [Pa] | Size H [mm] |
|-----|---------------------------|-------------|
| 1. | < 600 | 60 |
| 2. | 600–1000 | 100 |
| 3. | 1000–1400 | 140 |

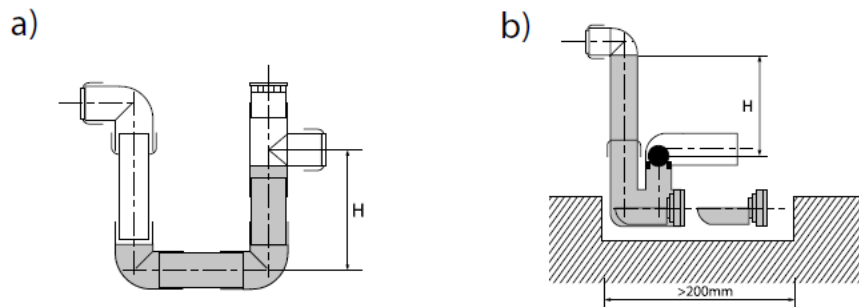

Fig.14 Types of siphons

4.2.7 Electric connection

Connection of electric AHU elements should be carried out by qualified personnel and should be done in accordance with any standards and regulations being in force in a country where the unit is installed. Cross section and type of cables (e.g. shielded cable) feeding individual functional segments should be selected basing on nominal current and specific operation conditions (e.g. ambient temperature, way of cabling, distance from the power supply).

Before starting connecting power supply, check conformity of the voltage and frequency of a supply network with the data shown on the device's rating plate. Permissible fluctuation of the supply voltage and its frequency to the values shown on the rating plate is $\pm 5\%$. If discrepancy exists, the device cannot be connected.

4.3 Service Access

The AHU shall be installed so that the connections of any related systems (ventilation ducts, pipelines, cabling, etc.) do not collide with the inspection panels.

Access to the internal elements of the units is possible by opening inspection panels. To remove the panel, unscrew few screws (1) fig.15 (numbers depend on the size of the section).

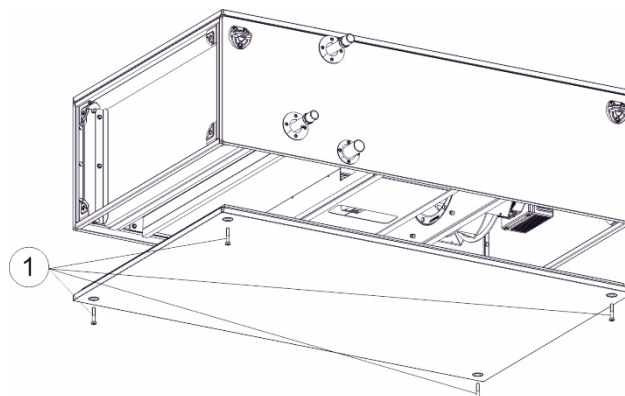

Fig.15 Removing inspection panel

4.3.1 Skid Removal

The unit ships on skids that provide forklift locations from the front or rear. The skid allows easy manoeuvrability of the unit during storage and transportation. Remove the skids before

placing the unit in its permanent location. Remove the skids using a forklift or jack. Lift one end of the unit off of the skids.

4.4 AHU components

4.4.1 Hydronic coil exchangers

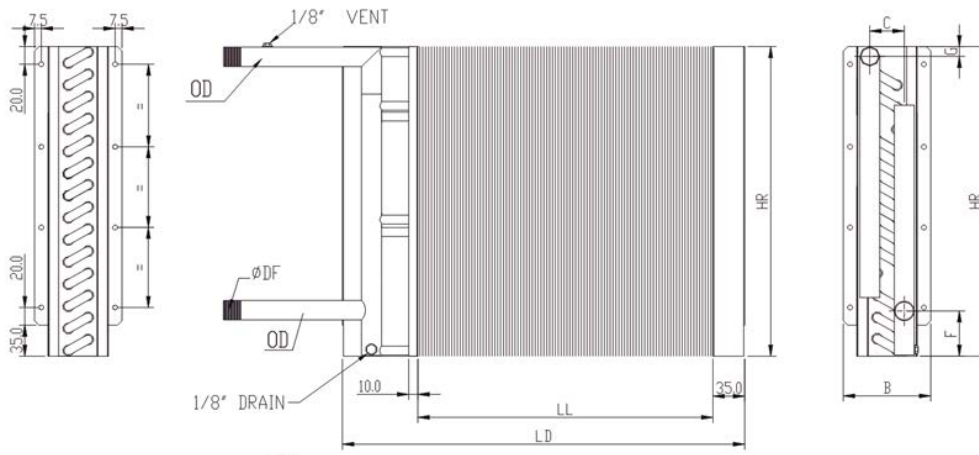

Fig. 16 Dimensions of hydronic coil exchangers

Table 4 Dimensions of hydronic coil exchangers of (Fig. 16)

| VSC Type | LL | LD | HR | B | C | F | G | OD | | Weight | Volume |
|--------------|------|-----|-----|-----|-----|----|----|----|------|--------|--------|
| | [mm] | | | | | | | | [mm] | [in] | [kg] |
| VVS005s WCL1 | 203 | 333 | 300 | 75 | 32 | 54 | 15 | 22 | 3/4" | 1,6 | 0,3 |
| VVS005s WCL2 | 203 | 333 | 300 | 96 | 32 | 54 | 15 | 22 | 3/4" | 2,0 | 0,5 |
| VVS005s WCL3 | 203 | 333 | 300 | 118 | 43 | 54 | 15 | 22 | 3/4" | 2,3 | 0,6 |
| VVS005s WCL4 | 203 | 333 | 300 | 140 | 65 | 54 | 15 | 22 | 3/4" | 2,9 | 0,8 |
| VVS005s WCL6 | 203 | 333 | 300 | 183 | 108 | 54 | 15 | 22 | 3/4" | 3,7 | 1,0 |
| VVS010s WCL1 | 403 | 513 | 300 | 75 | 32 | 54 | 15 | 22 | 3/4" | 2,3 | 0,4 |
| VVS010s WCL2 | 403 | 513 | 300 | 96 | 32 | 54 | 15 | 22 | 3/4" | 2,9 | 0,7 |
| VVS010s WCL3 | 403 | 513 | 300 | 118 | 43 | 54 | 15 | 22 | 3/4" | 3,5 | 1,0 |
| VVS010s WCL4 | 403 | 513 | 300 | 140 | 65 | 54 | 15 | 22 | 3/4" | 4,4 | 1,2 |
| VVS010s WCL6 | 403 | 513 | 300 | 183 | 108 | 54 | 15 | 22 | 3/4" | 5,9 | 1,7 |
| VVS015s WCL1 | 603 | 713 | 300 | 75 | 32 | 54 | 15 | 22 | 3/4" | 3,0 | 0,6 |
| VVS015s WCL2 | 603 | 713 | 300 | 96 | 32 | 54 | 15 | 22 | 3/4" | 3,9 | 0,9 |
| VVS015s WCL3 | 603 | 713 | 300 | 118 | 43 | 54 | 15 | 22 | 3/4" | 4,8 | 1,3 |
| VVS015s WCL4 | 603 | 713 | 300 | 140 | 65 | 54 | 15 | 22 | 3/4" | 6,2 | 1,7 |
| VVS015s WCL6 | 603 | 713 | 300 | 183 | 108 | 54 | 15 | 22 | 3/4" | 8,5 | 2,4 |
| VVS020s WCL1 | 603 | 743 | 375 | 75 | 32 | 54 | 15 | 22 | 3/4" | 3,4 | 0,7 |
| VVS020s WCL2 | 603 | 743 | 375 | 96 | 32 | 54 | 15 | 22 | 3/4" | 4,5 | 1,2 |
| VVS020s WCL3 | 603 | 743 | 375 | 118 | 43 | 57 | 18 | 28 | 1" | 5,9 | 1,6 |
| VVS020s WCL4 | 603 | 743 | 375 | 140 | 65 | 57 | 18 | 28 | 1" | 7,5 | 2,3 |

| | | | | | | | | | | | |
|--------------|-----|------|-----|-----|-----|----|----|----|------|------|-----|
| VVS020s WCL6 | 603 | 743 | 375 | 183 | 108 | 57 | 18 | 28 | 1" | 10,2 | 3,2 |
| VVS030s WCL1 | 900 | 1018 | 375 | 75 | 32 | 54 | 15 | 22 | 3/4" | 4,6 | 0,9 |
| VVS030s WCL2 | 900 | 1018 | 375 | 96 | 32 | 57 | 18 | 28 | 1" | 6,3 | 1,8 |
| VVS030s WCL3 | 900 | 1018 | 375 | 118 | 43 | 57 | 18 | 28 | 1" | 8,1 | 2,4 |
| VVS030s WCL4 | 900 | 1018 | 375 | 140 | 65 | 57 | 18 | 28 | 1" | 10,4 | 3,1 |
| VVS030s WCL6 | 900 | 1018 | 375 | 183 | 108 | 58 | 19 | 28 | 1" | 14,4 | 4,5 |

4.4.2 DX Coils

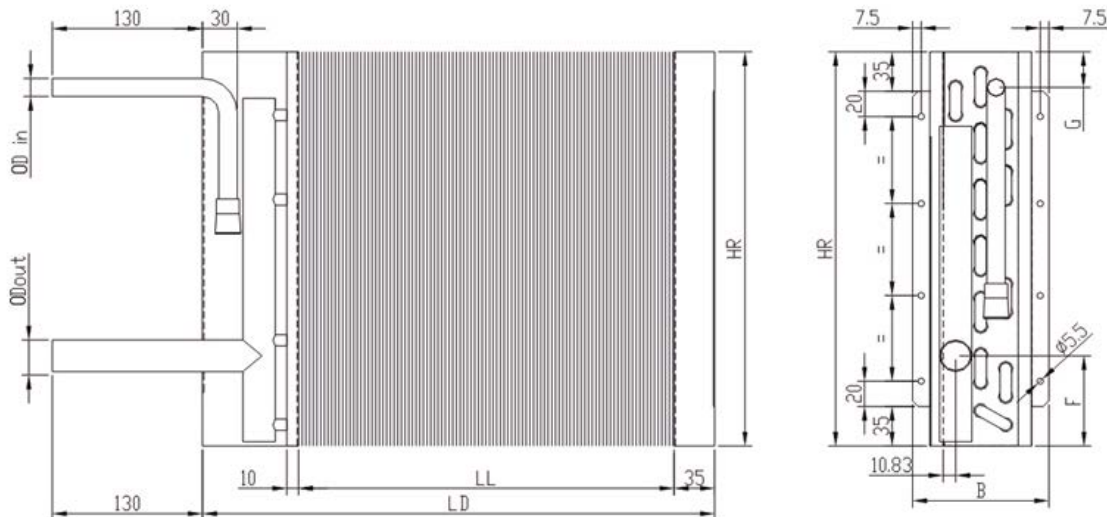

Fig. 17 DX coil drawing

Table 5 Dimensions of DX coils (Fig. 20)

| VSC Type | LL | LD | HR | B | C | G | F | OD in | OD out | Weight | Volume |
|----------------|------|-----|-----|-----|-----|----|----|-------|--------|--------|--------------------|
| | [mm] | | | | | | | | | [kg] | [dm ³] |
| VVS005s DX 2-1 | 203 | 333 | 300 | 96 | 32 | 19 | 80 | 16 | 28 | 1,7 | 0,4 |
| VVS005s DX 3-1 | 203 | 333 | 300 | 118 | 43 | 19 | 80 | 16 | 28 | 2,0 | 0,6 |
| VVS005s DX 4-1 | 203 | 333 | 300 | 140 | 65 | 19 | 80 | 16 | 28 | 2,5 | 0,7 |
| VVS005s DX 6-1 | 203 | 333 | 300 | 183 | 108 | 19 | 80 | 16 | 28 | 3,3 | 1,0 |
| VVS010s DX 2-1 | 403 | 513 | 300 | 96 | 32 | 19 | 80 | 16 | 28 | 2,6 | 0,7 |
| VVS010s DX 3-1 | 403 | 513 | 300 | 118 | 43 | 19 | 80 | 16 | 28 | 3,2 | 0,9 |
| VVS010s DX 4-1 | 403 | 513 | 300 | 140 | 65 | 19 | 80 | 16 | 28 | 4,1 | 1,2 |
| VVS010s DX 6-1 | 403 | 513 | 300 | 183 | 108 | 19 | 80 | 16 | 28 | 5,7 | 1,7 |
| VVS015s DX 2-1 | 603 | 713 | 300 | 96 | 32 | 19 | 80 | 16 | 28 | 3,6 | 0,9 |
| VVS015s DX 3-1 | 603 | 713 | 300 | 118 | 43 | 19 | 80 | 16 | 28 | 4,6 | 1,3 |
| VVS015s DX 4-1 | 603 | 713 | 300 | 140 | 65 | 19 | 80 | 16 | 28 | 5,9 | 1,6 |
| VVS015s DX 6-1 | 603 | 713 | 300 | 183 | 108 | 19 | 80 | 16 | 28 | 8,2 | 2,4 |
| VVS020s DX 2-1 | 603 | 743 | 375 | 96 | 32 | 19 | 80 | 16 | 28 | 4,2 | 1,1 |
| VVS020s DX 3-1 | 603 | 743 | 375 | 118 | 43 | 19 | 80 | 16 | 28 | 5,3 | 1,6 |
| VVS020s DX 4-1 | 603 | 743 | 375 | 140 | 65 | 19 | 80 | 16 | 28 | 6,9 | 2,1 |
| VVS020s DX 6-1 | 603 | 743 | 375 | 183 | 108 | 19 | 80 | 16 | 28 | 9,7 | 3,0 |

| | | | | | | | | | | | |
|----------------|-----|------|-----|-----|-----|----|----|----|----|------|-----|
| VVS030s DX 2-1 | 900 | 1018 | 375 | 96 | 32 | 19 | 80 | 16 | 28 | 5,8 | 1,6 |
| VVS030s DX 3-1 | 900 | 1018 | 375 | 118 | 43 | 19 | 80 | 16 | 28 | 7,5 | 2,2 |
| VVS030s DX 4-1 | 900 | 1018 | 375 | 140 | 65 | 19 | 80 | 16 | 28 | 9,8 | 2,9 |
| VVS030s DX 6-1 | 900 | 1018 | 375 | 183 | 108 | 19 | 80 | 16 | 28 | 13,9 | 4,3 |
| VVS030s DX 6-2 | 900 | 1018 | 375 | 183 | 108 | 19 | 80 | 16 | 28 | 17,1 | 4,3 |

4.4.3 Electric Heaters

Connecting power supply to the heater with control module should be done directly in the heater section, according to the guidelines of the module operation and maintenance manual. In any other case connecting power supply should be carried out with a separate switchgear, not supplied with the VTS package. Each heating unit of the heater is connected separately to the terminal strip, which is located sideways of the heating subassembly casing. Connection of the heater should be done in a way to prevent from possibility of switching on the heater when the fan is not switched on. What is more, if the fan stops, the heater's power supply must be turned off as well.

☑ **NOTICE!** The thermostat must be absolutely installed in the heater control system.

Thermostat functionality is based on the bimetal element properties, resulting in opening the heater control circuit contacts at air temperature near the thermostat up to 65°C. After emergency turn off, the heater turns on automatically once the air temperature goes down by 20°C. After intended or emergency (caused by overheating) turning off the power supply, the supply-air fan has to operate for some time (0.5–5 min), so as the heater's coils reached their normal temperature.

1. Overheating thermostat



- a) Functions and application
 - Protection module of the electric heater protecting it against overheating
- b) Construction
 - Metal casing
 - Two screw terminals
 - Bi-metallic element with a function of a normally closed contact

Depending on the automatics system, the heater's power can be adjusted smoothly or gradually. In order to control the heater gradually.

In suspended units, the electric heater is selected dynamically depending on the selected operating parameters. Number of heaters selected in the VVS005-020s control panels from 1 to 9 power of one 3kW heater. For the VVS030s control panel, the number of heaters from 3 to 6 the power of one 6kW heater. Heater cable power supply 3x400V.

- c) Operation parameters
 - activation temperature: 65±3°C
 - hysteresis: 17±3°C
 - parameters of bimetallic element voltage: 230VAC permissible load.
- 2. Differential pressure control



- a) Functions and application
 - Fan's pile-up control
- b) Construction
 - Membrane coupled with mechanical module. If the acceptable pressures difference is exceeded, the membrane undergoes deformation and switches off
 - casing: plastic
- c) Operation parameters
 - measurement: 20 – 300 Pa:
 - rated operational voltage 230VAC
 - output signal: voltage-free (switching contact)
 - number of cycles: <math><10^6</math> cycles

- operation conditions: -30 – +85°C
- protection class: IP44

Recommended pressure control operating position: horizontal. In case of vertical alignment, the set point value is 11Pa higher than the real one.

| | | | | <i>Compact suspended unit - Electric Heater</i> | | | | | | | | | | | | |
|---------|---------|---------|---------|---|--------|----------------------|--------|----------------------|--------|-------|--------|------|--------|----|--------|---|
| | | | | ID | Heater | | Fuse | Supply cable | Desc | Phase | | | | | | |
| | | | | | Power | Current | | | | L1 | L2 | L3 | | | | |
| | | | | | | | | L1-2 | | L1-3 | | L2-3 | | | | |
| VVS020s | VVS015s | VVS010s | VVS010s | 1 | 3 kW | 7,5 A | B10 | 4x1,5mm ² | Heater | H1 | 3000 W | - | - | - | - | - |
| | | | | Current | | 7,5 A | 7,5 A | - | - | | | | | | | |
| | | | | 2 | 6 kW | 13,0 A | B16 | 4x1,5mm ² | Heater | H1 | 3000 W | H2 | 3000 W | - | - | - |
| | | | | Current | | 13,0 A | 7,5 A | 7,5 A | - | - | | | | | | |
| | | | | 3 | 9 kW | 13,0 A | B16 | 4x1,5mm ² | Heater | H1 | 3000 W | H2 | 3000 W | H3 | 3000 W | - |
| | | | | Current | | 13,0 A | 13,0 A | 13,0 A | - | - | | | | | | |
| | | 4 | 12 kW | 19,5 A | B25 | 4x2,5mm ² | Heater | H1 | 3000 W | H2 | 3000 W | H3 | 3000 W | - | | |
| | | Current | | 19,5 A | 19,5 A | 13,0 A | - | - | | | | | | | | |
| | | 5 | 15 kW | 25,5 A | B32 | 4x4,0mm ² | Heater | H1 | 3000 W | H2 | 3000 W | H3 | 3000 W | - | | |
| Current | | 25,5 A | 19,5 A | 19,5 A | - | - | | | | | | | | | | |
| 6 | 18 kW | 26,0 A | B32 | 4x4,0mm ² | Heater | H1 | 3000 W | H2 | 3000 W | H3 | 3000 W | - | | | | |
| Current | | 26,0 A | 26,0 A | 26,0 A | - | - | | | | | | | | | | |
| VVS030s | VVS015s | VVS010s | VVS010s | 7 | 21 kW | 32,5 A | B40 | 4x6,0mm ² | Heater | H1 | 3000 W | H2 | 3000 W | H3 | 3000 W | - |
| | | | | Current | | 32,5 A | 32,5 A | 25,5 A | - | - | | | | | | |
| | | | | 8 | 24 kW | 39,0 A | B40 | 4x6,0mm ² | Heater | H1 | 3000 W | H2 | 3000 W | H3 | 3000 W | - |
| Current | | 39,0 A | 32,5 A | 32,5 A | - | - | | | | | | | | | | |
| 9 | 27 kW | 39,0 A | B50 | 4x6,0mm ² | Heater | H1 | 3000 W | H2 | 3000 W | H3 | 3000 W | - | | | | |
| Current | | 39,0 A | 39,0 A | 39,0 A | - | - | | | | | | | | | | |
| VVS030s | VVS015s | VVS010s | VVS010s | 1 | 6 kW | 15,0 A | B16 | 4x1,5mm ² | Heater | H1 | 6000 W | - | - | - | - | |
| | | | | Current | | 15,0 A | 15,0 A | - | - | | | | | | | |
| | | | | 2 | 12 kW | 26,0 A | B32 | 4x4,0mm ² | Heater | H1 | 6000 W | H2 | 6000 W | - | - | |
| | | | | Current | | 26,0 A | 15,0 A | 15,0 A | - | - | | | | | | |
| 3 | 18 kW | 26,0 A | B32 | 4x4,0mm ² | Heater | H1 | 6000 W | H2 | 6000 W | H3 | 6000 W | - | | | | |
| Current | | 26,0 A | 26,0 A | 26,0 A | - | - | | | | | | | | | | |
| 4 | 24 kW | 40,0 A | B50 | 4x6,0mm ² | Heater | H1 | 6000 W | H2 | 6000 W | H3 | 6000 W | - | | | | |
| Current | | 40,0 A | 40,0 A | 26,0 A | - | - | | | | | | | | | | |

| | | | | | | | | | | | | |
|--|---|--------------|--------|-----|----------------------|---------|----|--------|----|--------|----|--------|
| | 5 | 30 kW | 52,0 A | B63 | 4x6,0mm ² | Heater | H1 | 6000 W | H2 | 6000 W | H3 | 6000 W |
| | | | | | | | H4 | 6000 W | H5 | 6000 W | | - |
| | | | | | | Current | | 52,0 A | | 40,0 A | | 40,0 A |
| | 5 | 36 kW | 52,0 A | B63 | 4x6,0mm ² | Heater | H1 | 6000 W | H2 | 6000 W | H3 | 6000 W |
| | | | | | | | H4 | 6000 W | H5 | 6000 W | H6 | 6000 W |
| | | | | | | Current | | 52,0 A | | 52,0 A | | 52,0 A |

Table 6 Connection table for electric heaters

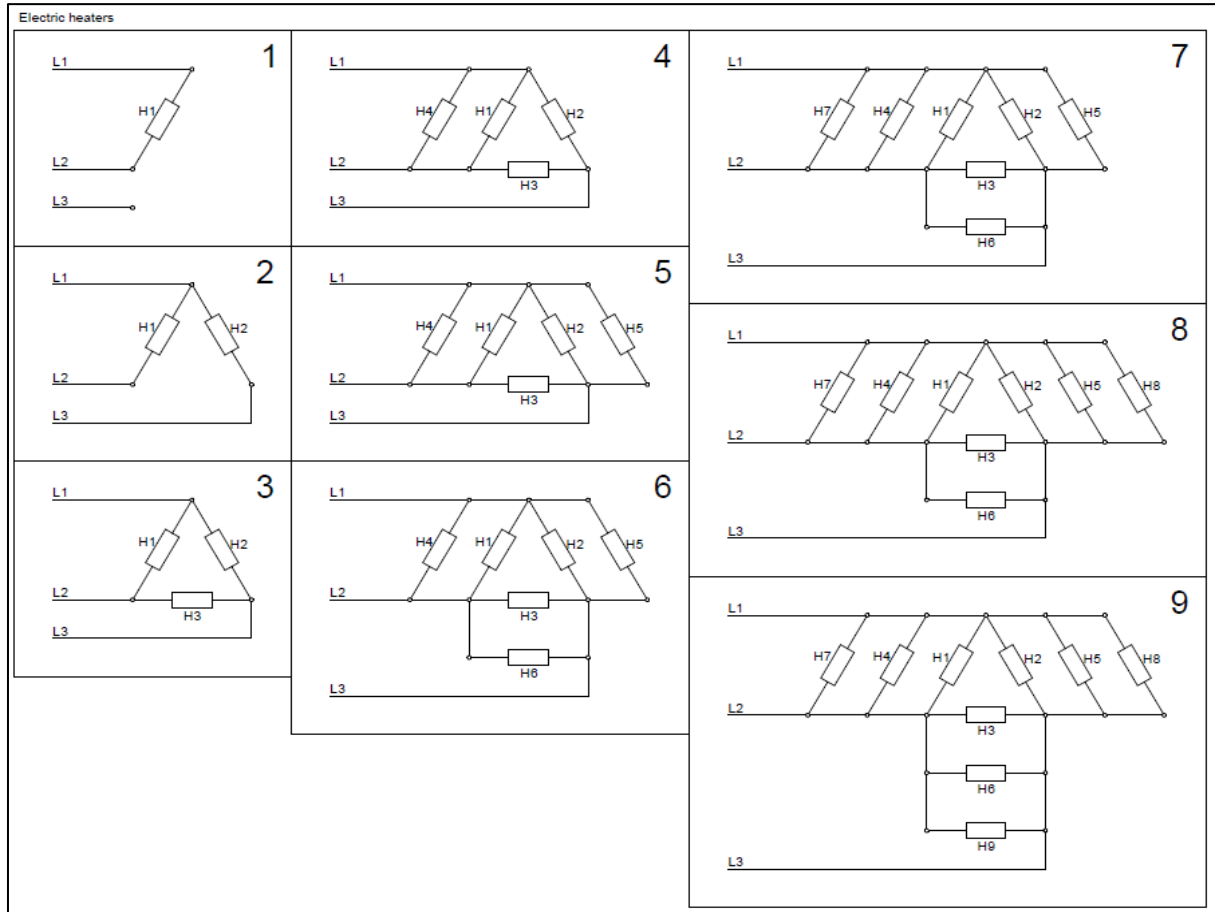

Fig. 18 Connection diagrams for electric heaters

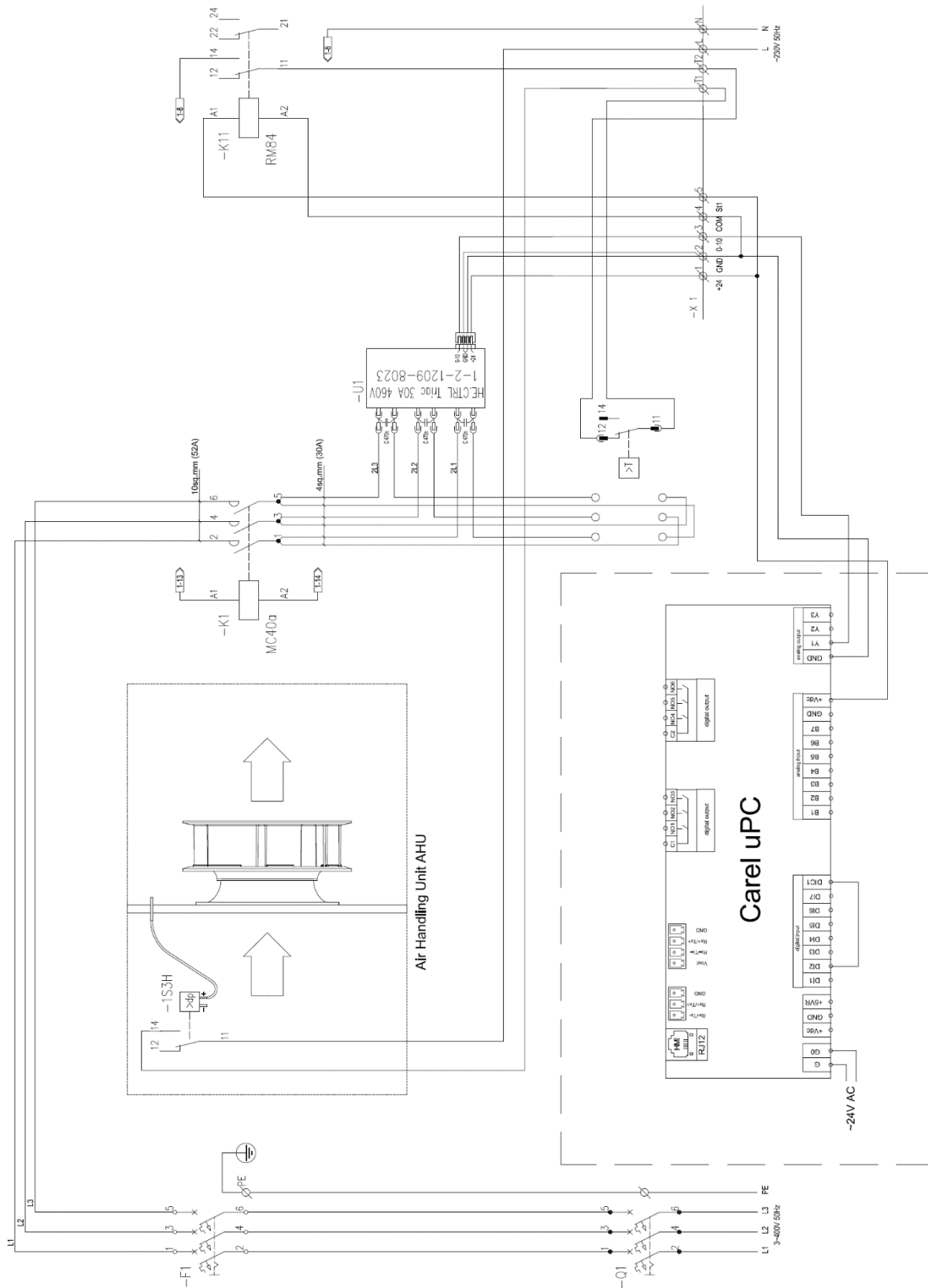

Fig.19a Electric heater connections with CG UPC

4.4.4 Fan's motors

The fan of suspended units are integrated with EC motors. Below table is showing data of motor and possibility of fan configuration:

| AHU size | Fan size | Nominal speed | Motor rated power | Supply voltage | Rated current |
|--------------------|----------|---------------|-------------------|----------------|---------------|
| | | rpm | [W] | [V] | [A] |
| VVS005s | 190 | 4490 | 169 | 1~230 | 1,2 |
| VVS010s VVS015s | 225 | 3600 | 370 | 1~230 | 1,56 |
| | | 4500 | 735 | 1~230 | 3,4 |
| | 250 | 3000 | 370 | 1~230 | 1,74 |
| | | 3800 | 735 | 1~230 | 3,67 |
| VVS020s | 250 | 3800 | 735 | 1~230 | 3,67 |
| VVS020s | 315 | 3690 | 2200 | 3~400 | 5,5 |
| VVS030s | 2x250 | 3800 | 735 | 1~230 | 3,67* |
| VVS030s | 315 | 3690 | 2200 | 3~400 | 5,5 |

*data for one motor

Motors of the fan sizes 190, 225 and 250 are integrated with control electronic. IP protection class of the motors with the controller is 44. The own electronics protect them against the overload, phase fail/lose, under and over voltage and phase over current.

Motors of the 315 fan is equipped with separate electronic drives. IP of the motor is 55 and separate inverter is 20.

The motor can be started by means of digital commands, bus commands references or local start command whenever the drive is connected to the AC line.

AHU section with counter-flow heat exchanger is completely cabled with full automation control. Details of the setting and configuration you can find in Automation chapter.

Supply and exhaust sections without heat recovery can be delivered with or without automation control.

Below figures shows connection cables and terminals of the motors.

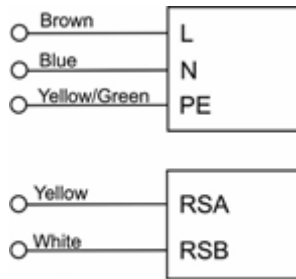

Fig.20 Motor connection cable for the fan of VVS 005s

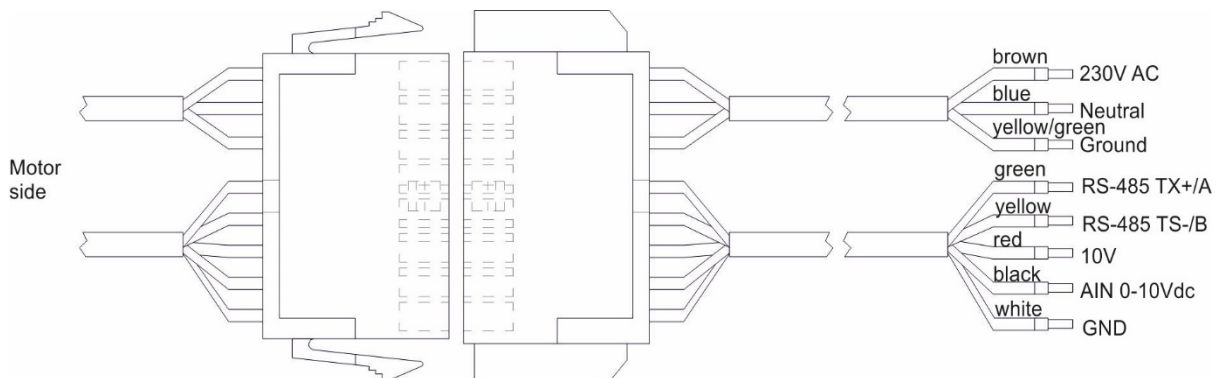

Fig.21. Motor connection cable for the fan of VVS 010-030

4.4.5 Air Filters

Pleated panel filters in three filtration classes respectively.

Table 7 Panel filters sizes

| AHU size | WxHxC [mm] | Filtration class |
|----------|-------------|------------------|
| VVS005s | 332x320x48 | M5, F7, F9 |
| VVS010s | 513x320x48 | |
| VVS015s | 713x320x48 | |
| VVS020s | 742x410x48 | |
| VVS030s | 1017x410x48 | |

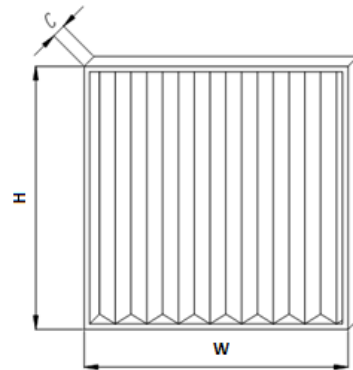

5 Automation

5.1 Description of controls

5.1.1 Introduction

Application:

Protection and control of supply and exhaust AHUs equipped with up to:

- two fan and two air dampers
- cooler, heater, heat recovery system

Range of operation: VVS005s–030s

Systems equipped with EC motors

5.1.2 Mains switch

Function: Switching the control gear

On



Off



5.1.3 Communication port



RJ11 – socket, is placed In front of the control gear housing

Function:

Connecting the HMI Advanced UPC control panel to the controller.

5.1.4 Signaling controller status



In the bottom left side of the controller, there are two LED indicators.

Orange LED indicates the condition of the power supply. LED off means no power supplied to the terminals or malfunction of internal power supply circuitry. LED on means correct parameters of the power supply.

Green LED indicates the condition of controller's BIOS. LED off means that the firmware is not running correctly. LED on means that BIOS runs OK and the controller is ready for operation.

- 1) All control gears need to be powered from the main switchgear equipped with appropriate protection of wires powering the control box.
- 2) Assembly, wiring and start-up of the control gear should be done by qualified staff only.
- 3) For applications subject to strong vibrations (1.5 mm pk-pk 10/55 Hz), secure the cables connected to the µPC using clamps placed around 3 cm from the connectors.
- 4) The entire length of the input/output connections must be less than 30 m, according to EN 61000-6-2.
- 5) Installation must be performed according to the standards and legislation in force in the country where the appliance is used.
- 6) In the event of malfunctions do not attempt to repair the controller, but rather contact the service.

The control gears it is not adapted to outdoor work without additional elements.



LCD Display

Displaying available parameters, settings and current values

BELL Button Jump to alarm handling pages

PRG Button

- 1) Quick jump to the Calendar main page
- 2) In Calendar pages – quick clear of the settings

ESC Button

Jump to the main page or leaving the parameter change

UP Arrow

- 1) Moving up across the menu screens (when the cursor stays in upper left corner)
- 2) Increasing the parametr value

ENTER Button

- 1) Moving the cursor across the screen – cursor jumps to the next parameter available for changing. Read-Only parameters are not marked with the cursor.
- 2) Confirming entered values
- 3) Entering sub-menus from the main menu level:
 - Parameters
 - Calendar
 - Alarms
 - Settings
 - Service

DOWN Arrow

- 1) Moving down accross the menu screens (when the cursor stays in upper left corner)
- 2) Decreasing the parameter value

Navigation example:

- 1) In the main menu level use UP/DOWN arrows to find the desired sub-menu
- 2) Press ENTER to go to the sub-menu level
- 3) Use UP/DOWN arrows to move across the sub-menu screens
- 4) In the desired screen, use the ENTER button to switch between the changeable parameters – the cursor starts from the upper left corner (which is the base

position) and jumps on and on until going back to the upper left corner – then the loop can be started again

- 5) To change the parameter marked with the cursor, use the UP/DOWN arrows
- 6) Press ENTER to go confirm the change and to jump further

Functions:

- Air handling unit operation, parameterization and maintenance
- Selection of control application
- Time zones setting
- Displaying and canceling alarm statuses, viewing alarm history

Note!

Parameters available in the LCD window depends on a AHU type and the control application. Hence in AHUs not equipped with heater, options related to the heating module will not be visible.

HMI Advanced UPC can't serve as a room temperature sensor.

5.1.5 Simplified control panel – HMI Basic UPC



1) LCD Display

Indicates actual room temperature or temperature on the main control sensor as well as a chosen setting, operation mode, fan speed, time and day of the week.

2) ON/OFF button

Switching between On/Off state (forcing the unit to stop or enabling operating mode selection)

3) Fan button

Button for mode setting: Auto / Low / Econo / Comfort

4) Clock button

Entering Auto mode. Controller will operate according to the time schedule stored in Calendar settings.

Note!

There are two options for time schedule operation. For details, follow manual for uPC3.

Note!

If the Calendar is also in Auto mode, the AHU operation will rely only on protective and energy saving functions like Standby and Night Cooling. This is possible for the main Calendar of the controller. The built-in Calendar of the HMI Basic doesn't support that functionality.

5) Push & Roll knob

Quick, intuitive and easy entering values, changing setpoints, accepting new values.

Note!

To change the temperature setpoint, just turn the knob.

Display of the room sensor temperature or the value of the temperature setpoint offset

Note! Setting is limited to 16..26°C

- Icons for active recirculation, cooling or heating
- Time indication
- Display of the fan speed setting or the indication of automatic fan mode
- Indications of the weekdays
- Icon for active recovery unit
- Icon for alarm event
- Icon for Off mode

Functions:

- Room temperature measurement and display
- Change and display of temperature setpoint
- Change and display of fan setpoint
- Display temperature of the main control sensor
- Change of AHU operation mode
- Info on alarm status

Optional element. Connects to the controller via the Modbus line, common with the frequency converters.

Web-Server / Modbus TCP/IP Option – Available as Expansion Card

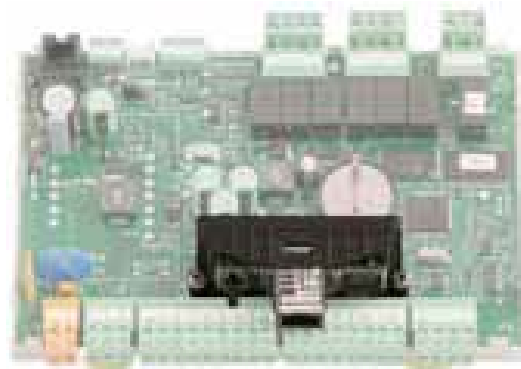

Gives extended access to read / write parameters like measurement readouts, setpoints, settings, output values, selected calendar settings, alarms. Total count of available parameters exceeds 200 datapoints.

SEE SPECIAL MANUAL FOR DETAILS OF EXPANSION CARD OPERATION

5.2 System Start-Up

Operation of the AHU is strictly arrested by the fire-protection alarm, activation of the thermal protection of fans' motors, threefold activation of the protection of electric heater and threefold activation of the anti-frost thermostat. Each of these events requires removing the cause of the alarm and then canceling it (see more details in Advanced Manual).

5.2.1 Switching on power supply

Switching on power supply of the control gear with the mains switch (Q1M). Correct power supply and good BIOS operation is indicated by yellow and green LED lamps on the controller's PCB.

The system is ready for operation after about half minute from switching on.

Note!

If the system did not start, check the F5 protection on power box status correct device operation depends on the application settings. Choosing and setting up the application should be done by qualified service provider, according to recommendations of part II "Advanced manual".

5.2.2 HMI Advanced UPC



Main menu structure

- 1) Main default screen with most important statuses and setpoints.
Set mode HMI – is used to set the main operating mode from the HMI.
Current mode – indicates current AHU mode resulting from HMI setting, alarms, external control signals etc.
Set temp HMI – is used to enter the main temperature setpoint from the HMI.
Current temp – temperature readout from the main sensor.
- 2) Second main status screen
Fans – indicates the current state and rate of the fans
Dampers – indicates the current state and opening rate of the dampers
Regulator – indicates the state and the output of the main controller for heating / cooling function
Recovery – indicates the state and rate of the heat recovery unit
EN/PL/RU – language selection
PASSWORD – is used to enter to special settings and hidden parameters
- 3) Sub-menu link screen
PARAMETERS – link to main statuses and readouts from the control system
- 4) Sub-menu link screen
CALENDAR – link to calendar settings and time schedule programming
- 5) Sub-menu link screen
ALARMS – link to alarm pages
- 6) Sub-menu link screen
SETTINGS – link to set and adjust the control system, regulators, timers
- 7) Sub-menu link screen
SERVICE MENU – link to main configuration parameters, application codes, AHU startup settings

All the menus are dynamically changed, as they depend on the application settings

5.2.3 Selection of operating mode

The AHU can operate in one of the following operating modes.

- **Auto – AHU operates depending on** – the calendar programming
HMI Basic
external control signals (binary inputs) critical temperatures, e.g. too low temperature causes AHU start and immediate heat-up of the room.
- **Off – AHU switched off** – fans stopped, dampers and control valves closed all sensors and gauges are activated – in order to protect the unit from damage, e.g. fire alarm, Frost protections.
- **ECO – Lower economy mode** – The fan speed and the dead zone for temperature regulation are adjustable. The temperature control algorithm can use broad deadzone and the fans can be set to low speed in order to reduce energy consumption.
- **Optimal – Upper economy mode** – The fan speed and the dead zone for temperature regulation are adjustable. The temperature control algorithm can use narrower dead zone and the fans can be set to higher speed in order to optimize energy consumption.
- **Comfort – Comfort mode** – The fan speed and the dead zone for temperature regulation are adjustable.

The temperature control algorithm can use most accurate dead zone and the fans can be set to highest speed in order to give maximum comfort.

Note!

The temperature setpoint is common for all operating modes, the dead zone settings are individual for each mode.

HMI BASIC

- 1) On/Off button – press to switch between Off and Low mode.
- 2) Fan button – press to switch operating mode between Low – Econo – Comfort
- 3) Clock button – press shortly to switch to Auto mode. In Auto mode Calendar will be capable of taking over the control.



5.2.4 Indication of operating mode

The following modes can be displayed in Current mode field in the main menu: Auto / Off / Low / Econo / Comfort as described above

- **Fire** – operating mode enabled by fire alarm input. All the devices switched off, the fans stop or run with selected setpoint (see chapter Service Menu)
- **OverRun** – AHU switches off, but the fans keep running on the idle speed until the heater is cooled down (see chapter Service Menu)
- **NightClg** – Night Cooling – a mode for energy saving by cooling down the room using cold air from the outside in the night. Available only in the units with external temperature sensor.
- **Standby** – protection mode for min/max room temperature – if the temperature exceeds specified setpoints, AHU is switched on, to heat up or cool down to desired range. Then switches off again.
- **NightKick** – testing mode, that forces fans to run in order to exchange the air in the ventilation system.

Note!

Night cooling and Standby functions rely on room temperature. If there's no measurement in the room, the exhaust duct sensor is taken into account and gives the readout. This requires turning on the fans to have appropriate room temperature value on that sensor.

- **InitHtg** – Initial Heating – a mode for startup of water heating units in winter conditions, heats up the coil before starting the fans in order to prevent activation of frost alarms.
- **Startup** – temporary mode when dampers are opening, fans speed up and the heating / cooling devices are enabled and start operation.
- **FastHtg / FastClg** – Fast Heating or Cooling – special mode for units with PCR or RRG recovery, that allows operation with

closed intake/outlet dampers and full recirculation. That improves heating up the building.

- **Heating** – mode when heaters can be enabled
- **Cooling** – mode when coolers can be enabled
- **Vent** – Ventilation – energy saving mode, when neither heaters nor coolers are enabled and the unit operates only with ventilation and optional recovery unit.
- **EmgStop** – Emergency Stop – unit forced to stop immediately, according to signal from optional digital input.
- **AlrStop** – Alarm Stop – unit forced to stop because of an alarm
- **CrtStop** – Critical Stop – unit forced to stop because of a critical alarm
- **Config** – unit forced to stop because the controller is in Config mode. Controller must be configured first and switched to Running mode

The unit can be controlled from several sources. Mind the priorities between them.

- 1) HMI Advanced (highest priority)
- 2) The BMS over Modbus TCP/IP connection
- 3) External control inputs
- 4) HMI Basic
- 5) The calendar mode

Note!

To enable another sources than the HMI Advanced, the Operating mode HMI must be set to Auto

5.3 Technical data

5.3.1 Operation parameters

| | |
|--|---------|
| System | TN |
| U3 rated power supply voltage | ~230V |
| Ui rated insulation voltage | 400 V |
| Uimp rated impulse withstand voltage | 2.5 Kv |
| rated short-time withstand current I _{cs} for respective circuits – effective value of alternating current component withstood during 1 second, i.e.: short-circuit current expected at rated connecting voltage | 6 kA |
| rated peak withstand current (ipk) at cosφ= 0.5 | 10.2 kA |
| rated short-circuit current | 6 kA |

| | |
|------------------------------------|-------------|
| coincidence factor | 0.9 |
| rated frequency | 50 Hz ± 1Hz |
| protection class | IP40 |
| acceptable operating temperature | 0 ÷ 40 °C |
| supply voltage of control circuits | 24 V AC |
| EMC environment | 1 |



5.3.2 Carel µPC controller

RESOURCES

Relay outputs Q1..Q7

| | | |
|-----------------------------------|--|-----------|
| Analog inputs B1..B6 | Reference GND; | potential |
| Outputs, DC 0–10V (1mA) | Reference GND; | potential |
| Binary inputs DI1..DI6 | Voltage free contacts Reference GND; | potential |
| Analog outputs Y1..Y3 | 0...10V, max 5mA Reference GND; | potential |
| RS485 communication port (J10) | Modbus 1200m | protocol, |

| | |
|---|--|
| | RJ45 socket |
| | 10/100 MBit (IEEE 802.3U) |
| Optional expansion card for Ethernet communication | Capable of: Parameter overview via Internet browser Modbus TCP/IP Server functionality via port 502 (datapoints specified by the end of that manual) |
| HMI Advanced comm. port (J7 or J8) | Serial link over RS485 connection Standard connection – factory supplied flat cable, 3m long |

5.3.3 Cabling

Connect power leads of the control gear and frequency converter of the fan drive according to the Electric diagram.

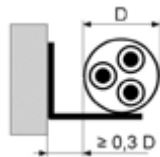



By default, Compact type AHUs have internal wiring. For motors, a fan diaphragm is equipped with a connection box on the inspection side. Power supply and ModBUS communication cables are connected to the junction box. VTS automation communicates with motors via the ModBUS RTU protocol. If it is necessary to use other automation and use the 0-10V DC signal, the user must change the cabling. A description of the pins available in this junction box is provided in the table below:

| connector marking | wire colour | function |
|-------------------|----------------------|------------------------|
| L1 | brown / black / gray | power supply – phase 1 |
| L2 | | power supply – phase 2 |
| L3 | | power supply – phase 3 |
| N | blue | power supply – neutral |
| PE | green – yellow | power supply – ground |
| A | green | ModBUS - RX+ |
| B | yellow | ModBUS – RX- |
| G | white | ModBUS - ground |

The wire cross-sections have been selected for long term current capacity for cables arranged in the air (supported on brackets, cable racks, in perforated trays) with spacing from the wall of min. 0.3 cable diameter, insulated with PVC, for 3-conductors loaded.

Due to the protection selectivity, length, cable placement method and short-circuit currents, revise the feeders' cross-sections in the table below.

| Wire type | Wire picture | Wire description | Parameters |
|-----------|---|---|---|
| [1] |  | Control wires with copper cores with a shield. PVC isolation. | Nominal voltage: 300/500 V Ambient temperature: – 30 to 80°C |

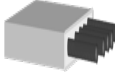
| | | | |
|-----|--|--|--|
| [2] |  | Copper cores. PVC isolation. | Nominal voltage: 450/750V Ambient temperature: from –40 to 70°C |
| [3] |  | Copper cores. PVC isolation. | Nominal voltage: 150 V Ambient temperature: – 20...60°C |
| [4] |  | Flat communication cable without shield. | Nominal voltage: 150V Ambient temperature: – 20...60°C |

| Name of element / connection point | Symbol | Wire type | Name of element / connection point |
|---|----------------------|-----------|------------------------------------|
| Controller | N1 | – | – |
| Fire alarm switch | S1F | [2] | 2x0,5 |
| Multi-function switch | S6 | [2] | 2x0,5 |
| Optional multi-function switch | S7 | [2] | 2x0,5 |
| Supply air temperature sensor | B1 | [1] | 2x0,5 |
| Room/ Return air temperature sensor | B2 | [1] | 2x0,5 |
| External air temperature sensor | B3 | [1] | 2x0,5 |
| HW back-water temperature sensor | B7 | [1] | 2x0,5 |
| HE alarm switch | VTS-E-005 ter. 22:23 | [2] | 2x0,5 |
| HW anti-frost air side thermostat | S2F | [2] | 2x0,5 |
| HW analog controlled valve | Y1 | [1] | 3x0,5 |
| CW analog controlled valve | Y2 | [1] | 3x0,5 |
| HE power rate control input | VTS-E-005 ter. 15:21 | [1] | 3x0,5 |
| HW circulating pump contactor | M1 | | 3x1,5 |
| Chiller / refrigerating unit / heat pump alarm switch | S5F | [2] | 2x0,75 |
| Chiller start input | E1 | [2] | 2x0,75 |
| Refrigerating unit start input – I stage | E2.1 | [2] | 2x0,75 |

| | | | |
|--|------|-----|-----------------|
| Refrigerating unit start input – II stage | E2.2 | [2] | 2x0,75 |
| Recirculation damper actuator | Y3 | [1] | 3x0,75 |
| Cross-flow bypass actuator | Y4 | [1] | 3x0,75 |
| AHU alarm | E4 | [2] | 2x0,75 |
| HMI Basic UPC – reduced function interface | N2 | [3] | UTP 1x2 |
| HMI Advanced UPC – full function interface | N3 | [4] | 8x0,1 |
| Supply elements | | | |
| Intake damper actuator | 1Y1 | [2] | 2x0,75 / 3x0,75 |
| Exhaust elements | | | |
| Redundant damper actuator – exhaust | 2Y1 | [2] | 3x0,75 |

5.4 Connection

5.4.1 Standard connection

The device in the standard version has full internal wiring. Equipment of the device:

- B2 – Temperature sensor – return
- H2 – Humidity sensor – return
- B4 – Temperature sensor – return after recovery
- B9 – Temperature sensor – supply after recovery

- 1S1H - Pressure control –primary filter, supply
- 1S3H - Pressure control – supply fan
- 2S1H - Pressure control – primary filter, supply
- 2S3H - Pressure control – return fan

Connected supply fan, return fan and sensor.

5.4.2 Power connection

From the user's side, the power supply and the main disconnector and external peripherals remain connected to Terminal 1.

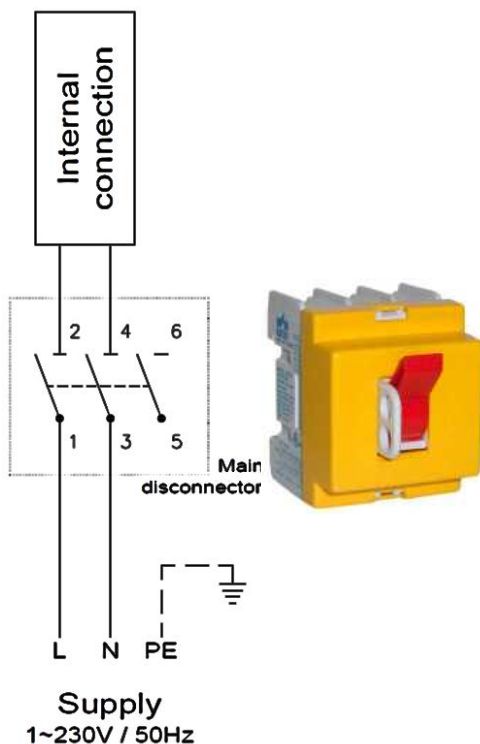

Power supply connection for circulation pump for the water heater, connector 1, N, PE at the main disconnector.

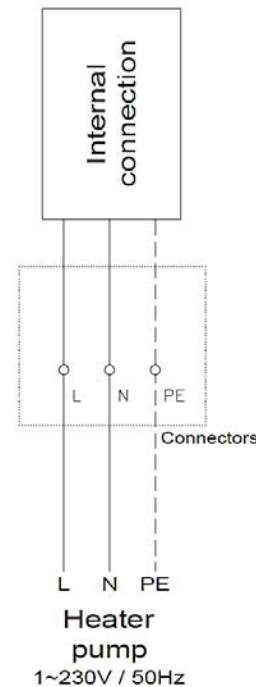

5.4.3 Connection of automation elements

Terminal 1

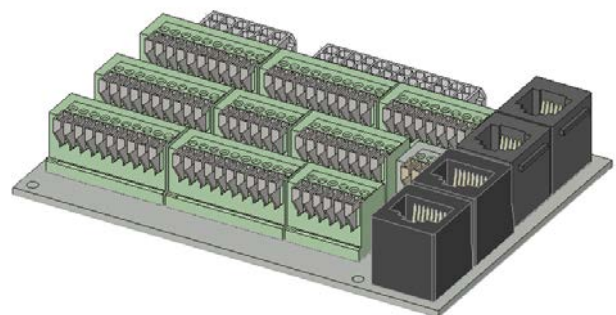

Terminal connection – HMI Advance (N3)

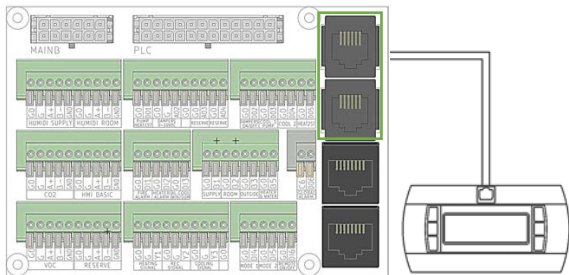

Analog output (0–10V DC)

- Y1 – Heating
- Y2 - Recovery
- Y3 - Cooling
- AO2 - Mixing damper



Analog input (NTC10k)

- B1 – Temperature sensor – supply
- B2 – Temperature sensor – return
- B3 – Temperature sensor – outside
- B7 – Temperature sensor – heater

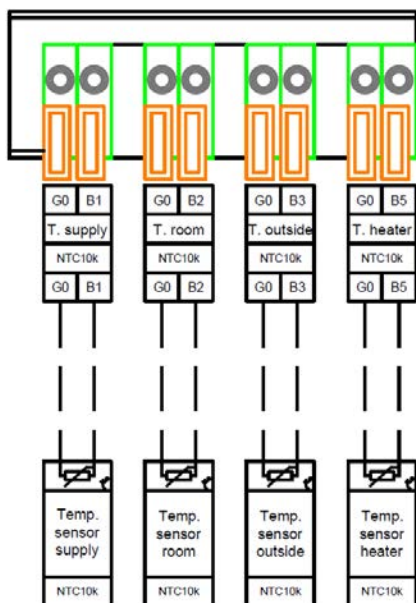
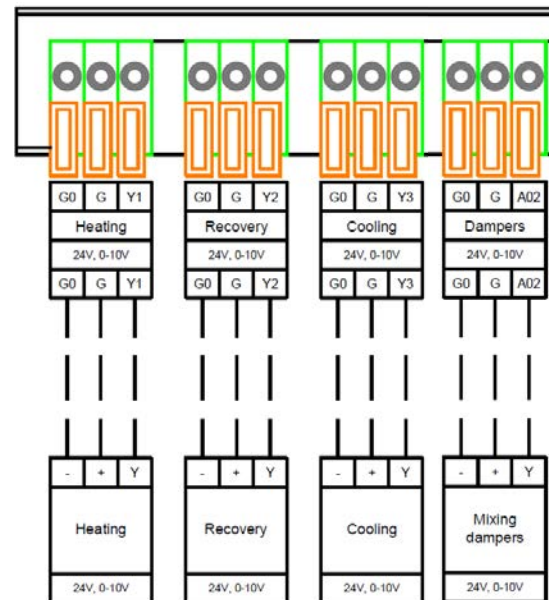

Digital output (24V DC)

- 1Y1 / 2Y1 - Dampers
- M1 - Heater 1
- Heater 2
- E1/E2.1 - Cooler 1
- E2.2 - Cooler 2
- E4 - Global alarm

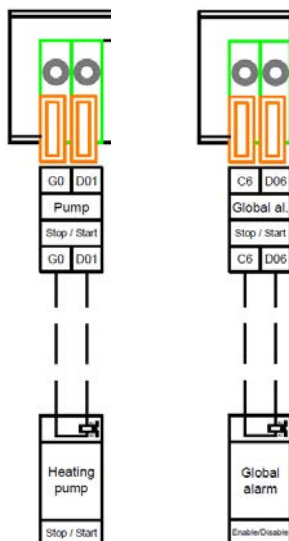
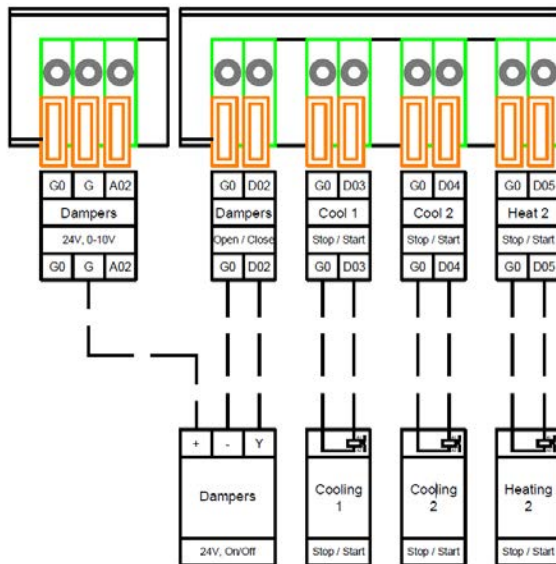

Digital input

- S1F - Fire alarm
- S2F - Heater alarm / Frost alarm
- S5F - Cooler alarm
- S6 - Mode 1
- S7 - Mode 2
- Remote

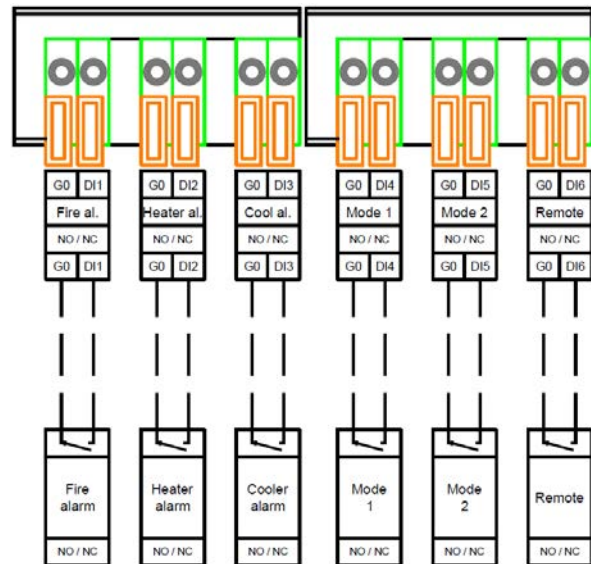

Communication **Modbus RTU – RS-485**

- Humidity sensor – supply
- Humidity sensor – room
- CO2 sensor
- VOC sensor
- HMI Basic

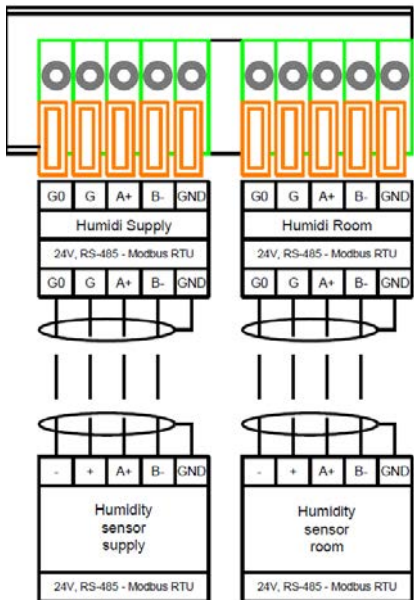
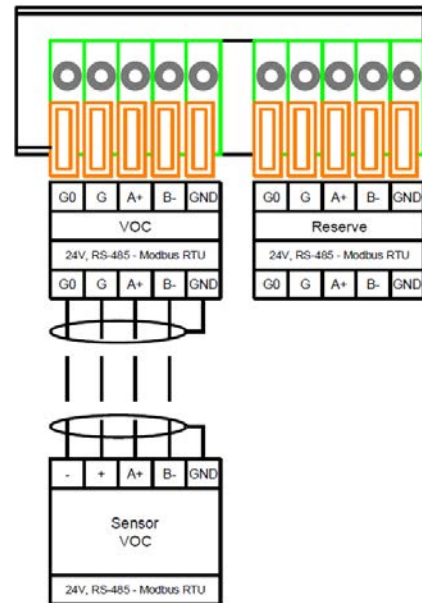
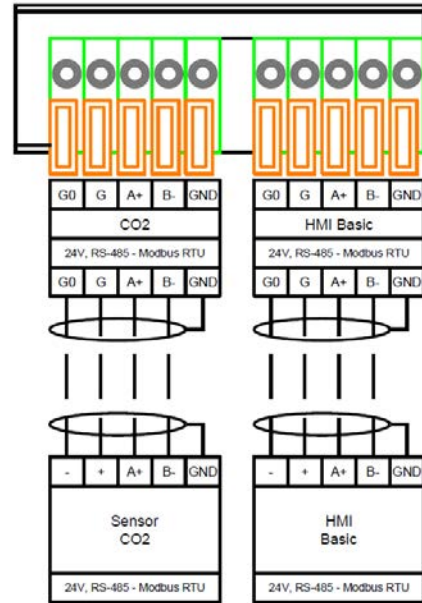

6 Preparation for start-up

AHU start-up at putting the ventilation system into service can be carried out only by qualified and competent personnel. Before starting-up the system and ducting must be thoroughly cleaned. Check if:

- during assembly operations systems and devices' elements as well as automatics elements and equipment were not damaged,
- all ventilation devices are mechanically installed and connected to the ventilation system,
- ground cables connecting the control gear with ventilation ducts are installed,
- hydraulic and freon systems are fully installed and ready for operation and heating or cooling medium is present during the start-up,
- electric devices are wired and ready for operation,
- siphons and condensate drain-out system from drain plate are installed,
- all automatics elements are installed and wired.

6.1 Electrical system

Before closing connecting boxes of the electric devices check the following:

- basing on appropriate electric diagrams – conformity of connections,
- application of protection units for all electric devices,
- fastening all screws and appropriate assembly of any supporting elements and electric connections (also unused support terminals – if any),
- cables and wiring – for conformity with all relevant safety, functional, cross-section, etc. regulations,
- appropriate ground and protection systems,
- inside of connecting boxes – if there are no loose or redundant cables left,
- condition of sealings and sealing surfaces.

- ☑ **NOTICE!** The AHU can only be operated with assembled filters.

Before closing the filtration section please make sure to:

- remove protective foil from filters,
- assemble filters in their slideways so as the bag were in vertical position,
- check filters' condition and leaktightness of fitting in the slideways,
- check settings of differential pressure controls (if they are applied) which determine permissible static pressure difference qualifying a filter for replacement.

6.2 Filters

Air filters in AHU prevent from getting dust into ventilated rooms. And what is more, they protect other AHU functional elements (e.g.: heat exchangers) against contamination.

Table 8. Permissible pressure difference

| Filter type and class | Permissible pressure difference |
|-----------------------|---------------------------------|
| G4 | 150 Pa |
| M5/F5/F7 | 200 Pa |
| F9 | 300 Pa |

6.3 Water heaters

Check the following:

- connection of supply and return pipelines,
- if the anti-frost thermostat's capillary is firmly attached to the heater's casing,
- setting of the anti-frost thermostat (factory setting: +5°C),
- if heater's control valve has been installed in accordance with markings shown on its casing.
- Water heater need antifrost thermostat.

6.4 Electric heaters

Check the following:

- electric connections, in accordance with electric diagrams for heaters' connection,
- connection of the protection thermostat,
- if the heating units do not touch other elements within the heating section,
- if the heaters' heating units are not damaged.

6.5 Water and freon coolers

As in case of water heaters, check the following:

- connection of supply and return pipelines,
- assembly of the siphon – fill it with water before starting the AHU up,
- patency of the condensate drain installation

6.6 Counter–flow heat exchangers

Check the following:

- condition of exchanger's lamellas (contamination, mechanical damages),
- assembly of the siphon – fill it with water before starting the AHU up,

6.7 Fan unit

Check if:

- there are no objects within a range of the fan, which might be sucked into the rotor once the fan is turned on,
- the fan's rotor rotates freely, without any friction against the casing elements,
- the motor is properly positioned and the system as well as operation conditions comply with data shown on the rating plate (supply voltage, current, frequency, winding connections),
- ground and protection connection are done correctly,
- all screws, supporting elements and electric connections are fasten firmly,
- supply cables located inside the fan section are far from any loose drive elements and they are fasten with appropriate clamps to the electric wiring,
- all dampers on the ventilation ducts network are set in accordance with the design,

Once the aforementioned control activities are performed, close carefully all AHU's inspection panels.

- ☑ **CAUTION!** Operation of the device with open inspection panels is forbidden.

7 Start-up and adjustment

The start-up is going to test if the AHU is made in accordance with the design and is ready for operation.

Start up and ventilation/air-conditioning systems adjustment can be done only by qualified and competent start-up personnel, equipped with necessary test devices.

After completing activities described in point 6 you can proceed with the first start-up. In case of AHUs equipped with secondary filtration section it is recommended to start up the system without the secondary filter insert.

The fan should be started with lower load and lead towards parameters similar to the operational ones. Lower load can be achieved by pushing the damper to on the AHU inlet and additionally, in case of powering the motor

through the frequency converter, by lowering the rotation speed.

During increasing the load, check all the time current consumed by the motor.

After start-up check if:

- there are no suspicious noises and unnatural mechanical sounds,
- there are no considerable AHU vibrations.
- The AHU should operate for about 30 minutes. After that time turn it off and inspect individual sections. Pay utmost attention to:
 - filters (if they are not damaged),
 - condensate drain-out,
 - fan unit.

Achieving required performance of the AHU depends, among the others, on carried out adjustment and test measurements.

7.1 Measurement of air quantity and AHU output adjustment.

Measurement of air quantity is a primary measurement in case of:

- AHU start-up and technical acceptance,
- when the system does not operate in line with the requirements and expectations,
- periodic control of AHU operation and performance,
- replacement of fan unit elements.

Before starting measurements and adjustment make sure if damper at all air grates or registers are adjusted in line with the design.

Determining quantitative air stream is based on the measurement of average air-flow speed in the ventilation duct test cross-section. One of the most common ways of determining average speed is the cross-section probing method with the Prandtl pipe and measurement of the speed-related average dynamic pressure.

Crucial factors influencing the measurement accuracy are:

- location of the measured cross-section in relation to the elements,
- quantity and location of test points in the measured cross-section,
- stable and constant air flow.
- It is highly recommended NOT to locate the measurement cross-section directly after:
 - network elements causing deformation of velocity speed (knees, reductions, three-way connections,
 - dampers, etc.),

- fan, because in the cross-section some reverse speed may appear.

The measurement should be carried out at the duct's fragment with parallel walls and straight segments at least 6 times longer than the duct diameter or equivalent diameters before the test point and not less than 3 diameters after it. In the real ventilation system finding such a long straight fragment can be a problem. In such a case determine the measurement cross-section in a place where the smallest distortions of air-flow are expected and intensify a network of test points. Location of the measurement cross-section should be determined on the system design stage.

We estimate the output being measured as sufficient unless it differs more than $\pm 10\%$ from the designed one. In case of bigger disproportions, the output alike the designed one can be achieved by:

- adjustment of the ventilation ducts network,
- changing adjustment of the main damper,
- changing the fan rotary speed.

7.2 Heat output adjustment of water heater

Heater output adjustment is proceeded by setting appropriate amount of air passing through the AHU.

Heater output adjustment consists in checking the heater's performance from the air's side through temperature measurements in front and behind the heater, at designed supply and return temperature values and amount of heating medium in the system.

Heater's output is controlled by adjustment of water supply temperature. It is achieved by mixing up in the three-way valve supply water with high temperature and water coming back from the heater, with lower temperature.

Once mixed, water getting to the heater reaches appropriate temperature – depending on the mixing level.

External conditions, similar to the rated ones occur within an annual cycle during relatively short period. In most cases you have to take into consideration the fact that the adjustment must be carried out in intermediate conditions, which must be recalculated in order to conform to the rated values.

Checking operation of the anti-frost thermostat is possible only when temperature of air supplied onto the exchanger is lower than the thermostat setting (factory setting: +5 0 C). It is safe to carry out this activity when the supply air temperature is 1–2 degree above 0°C. Then, when the AHU is running, cut for a moment the inflow of heating medium and watch if the thermostat is triggered. This operation should be carried out before putting the AHU into service.

7.3 Adjustment of electric heater

Smooth control of heater power is carried out by applying the VTS controls.

Perform simulation of lower power requirement by decreasing the set temperature value so as all electric steps (contactors) were in off position. Next increase significantly the setting and check if all electric steps turn on in the order in accordance with the operation description. Restore the previous temperature setting.

Also check operation of overheating protection in case of lack of air-flow. To do so, reduce the air-flow stream flowing through the heater by pushing to the inlet damper or by reducing the fan's speed.

⊗ **NOTICE!** During AHU operation speed of air flowing through the heater should not be lower than 1.5 m/sec.

Please note that the lower air-flow is the more possible it is to overheat the system.

7.4 Adjustment of cooler performance

Adjustment of cooler performance should be carried out in conditions similar to the rated ones. As in case of the heater, the effect from the air side is considered, including temperature and humidity in front and behind the cooler.

Temperature of cooling agent is controlled this way as well. If cooler operation effect is not satisfactory,

appropriate adjustment is required. It can be carried out using the following methods:

- adjustment of cooling medium amount (water coolers),
- adjustment of air amount passing through the AHU (water cooler and coolers with direct medium

- evaporation),
- adjustment through changing evaporation temperature (in case of systems with direct evaporation).

Coolers operate in most cases in complex air-conditioning systems equipped with automatic control.

Automatic control devices should be tested not only in extreme conditions but also in intermediate cooler load circumstances.

8 Operation and maintenance

☑ **NOTICE!** Personnel in charge of AHU operation should read through this documentation before starting any operation and maintenance activities. When no such personnel with appropriate skills and competence is available, periodic inspections should be carried out by the authorized VTS Service providers.

☑ **NOTICE!** Any damages of the AHU or its parts resulting from not following the guidelines stated in this documentation will not be subject to warranty claims.

Basic AHU technical data such as type, parameters and dimensions of the most significant parts (filters, heat exchangers, fans, electric motors) are provided in the Technical Data Card supplied with each device.

☑ **CAUTION!** Any AHU maintenance operations should be carried out with the device turned off.

In order to ensure safe device operation, a service switch cutting off power supply to the motor during service operation must be installed outside the fan section. Switching off the power circuit with the service switch must be held in non-voltage state. The service switch should be located close to the inspection panels of the fan section.

Thorough and regular maintenance as well as technical inspections of the AHU and its components are necessary in order to find the failures at their early stage – before more serious damages appear.

This documentation only covers general guidelines regarding control periods ensuring error-free operation of the AHU due to various possible external conditions of AHU operation. Control periods must be adapted to local conditions (contamination, number of start-up cycles, load, etc.).

Personnel in charge of the AHU should from the first AHU start-up keep up-to-date records making use of the "Inspections and maintenance table" which is Included in the Warranty Card. Any routine works related to the AHU operations should be recorder there. Carefully kept register is the only reliable document stating the unit operation condition, dates of current inspections, identified problems, etc. In case of contact with the VTS representatives always use the AHU factory identification number, located on the casing as well as in the AHU documentation.

Duration of periods between particular actions have been determined with assumption that the AHU works "non-stop" in low-dust environment and with no other disadvantages deteriorating the operation conditions.

In environments with high level of dust in supply or exhaust air, the inspections should be carried out more frequently.

AHU spare parts and accessories can be ordered at local authorized VTS service provider. While ordering parts please use the type and factory identification number of the device. This information can be found on the rating plate located on the fan section.

8.1 Dampers

If the damper is contaminated and does not operate freely it should be cleaned in one of the following ways:

- with industrial vacuum cleaner with soft suction nozzle,
- blow through with compressed air,
- wash with water under pressure with cleaning agents which do not cause aluminum corrosion.

The damper should be accurately sealed after re-assembly, first of all from the side of external air, otherwise the water heater can be frozen.

8.2 Filters

In standard AHU operation conditions the filters should be replaced circa each twice a year. Necessity of replacing the filter (beside the visual contamination) is also indicated by pressure drop according the data shown in Table 8.

The AHUs can be equipped with the following filters:

- P.FLT panel filters, M 5, F 7 and F 9 class

If the final pressure difference exceeds designed value, it must be replaced. Filters are disposable elements.

During filter replacement also clean the filtration section – vacuum or dry cleaning.

In case of ordering a new filter set at the VTS authorized service provider, provide filter type, filtration class, AHU size and, if needed and size according to the table 8.

The AHUs always have to operate with installed air filters, otherwise fans power consumption may exceed designed values, which may lead to damage of the motors.

8.3 Heat exchangers

8.3.1 Water heater

Operating water heaters should be equipped with anti-frost system. Optionally, in winter period replace heating medium of the heater with antifreeze medium (e.g.: glycol solution). In case of cutting off inflow of heating medium or operational standstill of the AHU and if air temperature may drop below + 5°C, the heater should be emptied.

In order to do so, please:

- close the valves at the heating agent's inflow and outflow (cut the heater off from the heating system)
- remove the inspection panel
- unscrew the drain and the vent plug from collectors
- connect the outflow hose to the drain to let the water go out of the drained exchanger outside the AHU
- blow through the heater with compressed air connected to the vent
- repeat this procedure several times at short intervals until only air goes out of the drain hose without any visible drops of water
- screw the drain and vent plugs back

Check contamination level of heater's lamellas at least every four months. Dust deposition on the heater surface deteriorates the heater's.

heating power and lead to pressure drop on the air side. Even if the AHU is equipped with filters, with time from the air supply side, dust settles onto the heater's lamellas. In case of contamination, cleaning should be carried out in one of the following ways:

- with a vacuum cleaner with soft suction nozzle from the air inlet side,
- by blowing through with compressed air in a direction opposite to normal air flow direction, directing air stream in parallel to the lamellas,
- washing with warm water with cleaning agents which do not cause aluminum or copper corrosion.

Before starting washing protect neighboring AHU sections against discharged dirt.

In order to achieve max. heating output of the heater, it must be well vented. Venting plugs are designed to do so and they are placed on heater's collectors.

During the AHU standstill, flow of the heating medium should be reduced to minimum so as temperature inside the AHU does not exceed + 60°C. Exceeding this value may lead to damage of some elements or subassemblies (motor, bearings, plastic elements, etc.) installed in the neighboring sections.

8.3.2 Electric Heater

Electric heater's battery consists of bare heating coils. During AHU operation, when the heater

does not work, dust may settle onto the heating coils. Once the heater is turned on again, strong

contamination may cause smell of burning dust or even preliminary fire danger may appear. Check regularly (every 4 months) and especially before starting a heating period, any electric connections, condition of heating elements and their contamination level. Any

possible contamination should be removed with a vacuum cleaner with soft suction nozzle or with compressed air.

Also check operation of overheating protection in case of lack of air-flow. Air speed should not be lower than 1.5 m/s.

8.3.3 Water cooler

Contamination level of the cooler should be checked each four months. If necessary, the cooler can be cleaned applying methods of cleaning the water heater.

Before starting washing protect neighboring AHU sections against discharged dirt.

While checking contamination level, check the droplet eliminator status as well as passability

of water siphon. The water siphon should be filled with water before starting up the AHU.

If the condenser is contaminated it should be washed with warm water with some cleaning medium.

In order to achieve max. output of the cooler, it must be well vented. Venting plugs are designed to do so and they are placed on cooler's collectors.

8.3.4 Freon cooler and heater

Maintenance of freon cooler covers the same range as the water heater and cooler. While washing the freon cooler with warm water, the cooling system should be emptied by sucking

off freon to the container. Otherwise there is a risk of uncontrolled increase of freon pressure and damage of the cooling system.

8.3.5 Counter flow heat exchanger

Check the exchanger every four months and inspect its technical condition as well as contamination level. Dirt accumulation in plate heat exchangers is often limited to the first 50mm in the exchanger. Before starting washing protect neighboring AHU sections against discharged dirt.

Necessary cleaning should be carried out using:

- vacuum cleaning with soft suction nozzle,
- blowing through the ducts with air stream in a direction opposite to the normal air flow direction,
- washing the air ducts at their whole length with water with cleaning agents which do not cause aluminum corrosion,
- in case of very contaminated exchangers you can use stream of compressed water to clean them.

While cleaning the exchanger using mechanical cleaning agents pay utmost attention not to damage or deform the exchanger's panels.

During exchanger operation in below zero temperature, the exchanger must be thoroughly dried before next start-up.

To access the counter-flow heat exchanger in the VVS005s-030s one should disassembly the drain pan from the unit. To do it, disconnect the drain pan from the drain installation, disassembly header connection glands, take off the plastic extension pipes and unscrew drilling screws fixing drain pan as in the figure below.

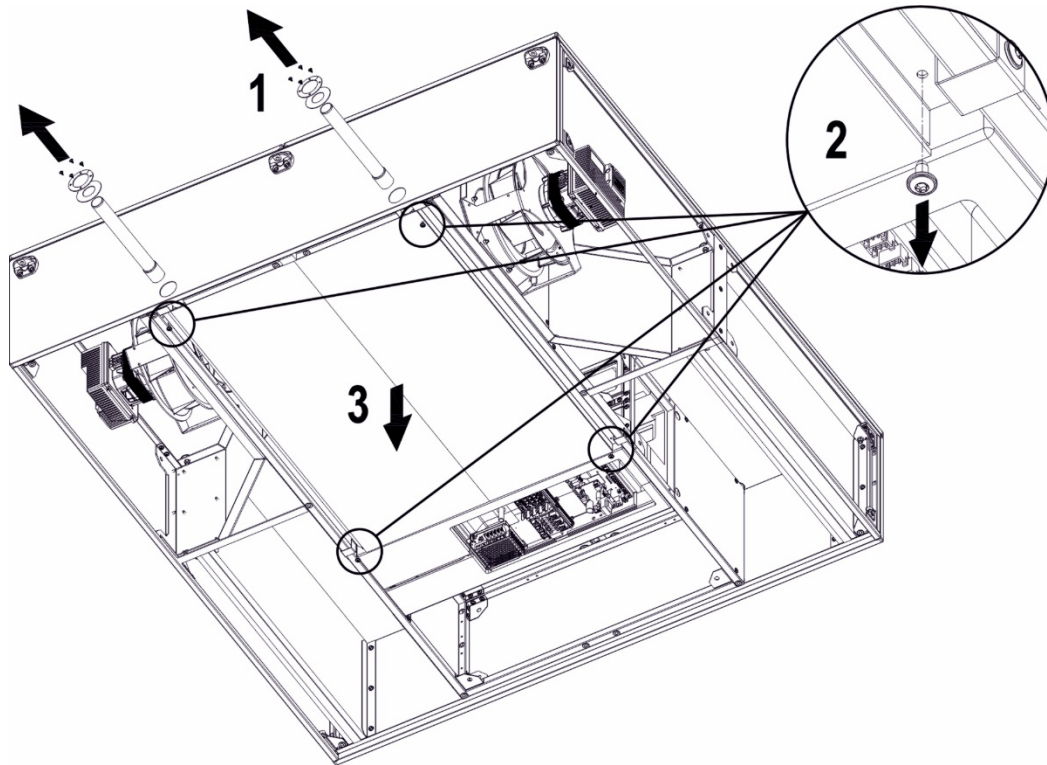

Fig.22. Access to the counter-flow heat exchanger in the unit VVS005s–030s

8.4 Silencer section

Silencer section is equipped with baffles with non-flammable mineral wool absorbing acoustic energy. Maintenance procedures entail checking contamination level of the baffles.

Cleaning should be performed with a vacuum cleaner or wet wiping of all surfaces. In case of more serious contamination you can use nylon brushes.

8.5 Fan unit

Before starting any kind of works (failure, maintenance, servicing) with AHU, especially in case opening the inspection panels of fan section as well as removing cover plates under the drive, please make sure if:

- the device has been properly disconnected from power supply. It applies to both main and secondary circuits,
- rotor is not rotating,
- fan is cold and the surface temperature is safe,
- the fan is protected against unintended start-up.

Fans are designed for transferring dust-free of light-dusted air. They are not designed for aggressive gases, steams or heavy-dusted air. Operating the fan in not suitable environment can lead to damage of bearings, corrosion, unbalanced rotor or vibrations.

The fan and motor in the unit are designed for particular requirements and operation

characteristics. Fan rotation speed is adapted so as the air stream and complete fan stress concentration were appropriate for a given ventilation system. Smaller stream of forced air results in disturbances in correct operation and leads to loss of balance of the entire ventilation system. It can be caused by:

- dust settlings on the fan's rotor blades,
- incorrect direction of fan's rotations. If the centrifugal fan rotates in incorrect direction, the air flow is carried out with significantly deteriorated output.
- In case of fan maintenance activities check if:
 - the rotor rotates freely,– the rotor is well balanced,
 - the rotor is firmly mounted on pivot,
 - did not change a location against the inlet cone,
 - all screws fastening construction elements of the fan unit are tight.
- Lack of rotor's balance can be caused by:

- dust settlings on the rotor's blades,
- detachment of additional balancing weights,
- damage of the rotor's blades.

Checking the contamination level of the casing inside, rotor and motor should be carried out

every four months and the following elements should be cleaned:

- casing inside with a vacuum cleaner,
- rotor with a vacuum cleaner or by wet wiping with soft cleaning agent.

9 Safety instructions

- Connection and start-up of the AHU should be carried out by qualified personnel in accordance with recommended and designed regulations and guidelines regarding operation of electric devices.
- In no circumstances you are allowed to connect the device to power supply before connecting the protection system.
- In no circumstances you are allowed to carry out repairs or maintenance works if the device is connected to power supply.
- Operation of the AHU with removed inspection panel is strictly forbidden.
- Personnel operating, repairing or providing maintenance services on the AHU must be qualified and authorized to carry out these activities in line with regulations being in charge in a country where the AHU is assembled.
- AHU assembly location must be equipped with necessary safety and fire protection equipment in line with local regulations.

10 Information

Routine inspections carried out by qualified technical personnel or by VTS Authorized Service Providers guarantee long-term, reliable and failure-free operation of the device. Our service personnel is always available to accompany you during the start-up, maintenance and in case of any other emergency related to the device operation.

VTS Authorized Service Providers sell spare parts and accessories for our AHUs. While ordering parts please provide the AHU type and size as well as its serial number. You can find more info regarding the network of VTS service providers at www.vtsgroup.com

11 Technical information to the regulation (U) No 327/2011 Implementing directive 2009/125/EC

| Model: | 19/0,16 EC | 22/0,37 EC | 22/0,75 EC | 25/0,37 EC | 25/0,75 EC |
|--------|---|---------------------------------------|--|------------------------------------|-------------------------------------|
| 1. | 60,2 | 60,8% | 60,8% | 60,8% | 60,1% |
| 2. | A | | | | |
| 3. | Static | | | | |
| 4. | 62 | | | | |
| 5. | Yes | | | | |
| 6. | 2018 | | | | |
| 7. | VTS, Poland | | | | |
| 8. | 1-2-0294-1750 | 1-2-0294-1547 | 1-2-0294-1548 | 1-2-0205-4001 | 1-2-0205-4003 |
| 9. | 169W, 540m ³ /h, 450Pa | 370W, 1300m ³ /h, 700Pa | 750W, 1550m ³ /h, 1150Pa | 370W, 1550m ³ /h, 620Pa | 750W, 1950m ³ /h, 1000Pa |
| 10. | 4030RPM | 3600RPM | 4500RPM | 3000RPM | 3800RPM |
| 11. | 1 | | | | |
| 12. | <p>Disassembly of the machine must be carried out and/or supervised by qualified personnel with appropriate expert knowledge. Contact a certified waste disposal organization in your vicinity. Clarify what is expected in terms of the quality of dismantling the machine and provision of the components.</p> <p>Dismantle the machine using the general procedures commonly used in mechanical engineering.</p> <p>WARNING</p> <p>Machine parts can fall The machine is made up of heavy parts. These parts are liable to fall during dismantling. This can result in death, serious injury, or material damage.</p> <p>Follow the safety rules:</p> <ol style="list-style-type: none"> 1. Disconnect all electrical connections. 2. Prevent reconnection. 3. Make sure that the equipment is at zero voltage. 4. Cover or isolate nearby components that are still live. <p>To energize the system, apply the measures in reverse order.</p> <p>Components:</p> <p>The machines consist for the most part of steel and various proportions of copper, aluminum and plastics (impeller made of SAN - styrene, acrylonitrile, construction material with 20% glass fiber). Metals are generally considered to be unlimitedly recyclable.</p> <p>Sort the components for recycling according to whether they are:</p> <p>Iron and steel, aluminum, non-ferrous metal, e.g. windings (the winding insulation is incinerated during copper recycling), insulating materials, cables and wires, electronic waste, plastic parts (impeller, winding cover ect.). The same goes for cloths and cleaning substances which have been used while working on the machine.</p> <p>Dispose of the separated components according to local regulations or via a specialist disposal company.</p> | | | | |
| 13. | <p>Long failure-free operation depends on keeping the product/device/fan within performance limitations described by selection software or maintenance manual.</p> <p>For proper operation, read carefully maintenance manual, with special attention on "installation", "start-up", and "maintenance" chapters.</p> | | | | |
| 14. | no additional elements | | | | |