



VENTUS Compact Air-Handling Units

Operation and Maintenance Manual

ventus

DTR-VVS-ver.2.6 (09.2020)

OPENING THE INSPECTION PANELS WHEN THE UNIT IS RUNNING OR STARTING THE UNIT WITH OPEN INSPECTION PANELS ARE STRICTLY PROHIBITED!

BEFORE OPENING THE INSPECTION PANEL TURN OFF THE UNIT AND WAIT TWO MINUTES SO ALL MOVING PARTS WOULD STOP!

SWITCH OFF AND PROTECT THE POWER SUPPLY TO PREVENT THE UNIT FROM UNINTENDED STARTING

1 Table of Contents



1	Table of Contents	3
1.	Introduction	6
2.	Application and design	6
3.	General Information.....	7
4.	Pre-Installation	11
4.1.	Transport and storage	11
4.1.1.	Receiving Checklist	12
4.2.	Installation Preparation.....	12
4.2.1.	Foundation	13
4.2.2.	Service Access.....	15
4.2.3.	Unit Location Recommendations	15
4.3.	Joining the AHU sections and connecting the ventilation ducts	15
4.4.	Connection of heaters and coolers	17
4.5.	Draining out condensate	20
4.6.	Electric connection	21
4.7.	AHU components	21
4.7.1.	Hydronic coil exchangers.....	21
4.7.2.	DX coils	23
4.7.3.	Electric heater	25
4.7.4.	Fan's motors.....	26
4.7.5.	Air Filters	27
4.7.6.	Rotary heat exchanger.....	27
4.7.7.	Counter-flow heat exchanger.....	27
5.	Automation	28
5.1.	Description of controls	28
5.1.1.	Introduction.....	28
5.1.2.	Mains switch.....	28
5.1.3.	Communication port	28
5.1.4.	Signaling controller status	28
5.1.5.	Simplified control panel – HMI Basic UPC	29
5.2.	System Start-Up.....	30
5.2.1.	Switching on power supply.....	30
5.2.2.	HMI Advanced UPC.....	31

5.2.3.	Selection of operating mode	31
5.2.4.	Indication of operating mode.....	32
5.3.	Technical data	33
5.3.1.	Operation parameters.....	33
5.3.2.	Carel μ PC controller.....	34
5.3.3.	Cabling.....	34
5.4.	Connection	36
5.4.1.	Standard connection	36
5.4.2.	Power connection.....	36
5.4.3.	Connection of automation elements.....	37
6.	Preparation for start-up	41
6.1.	Electrical system.....	41
6.2.	Filters.....	41
6.3.	Water heaters	42
6.4.	Electric heaters.....	42
6.5.	Water coolers, freon coolers and heaters.....	42
6.6.	Rotary exchanger	42
6.7.	Counter-flow heat exchangers	42
6.8.	Fan unit.....	42
7.	Start-up and adjustment	43
7.1.	Measurement of air quantity and AHU output adjustment.....	43
7.2.	Heat output adjustment of water heater.....	44
7.3.	Adjustment of electric heater	44
7.4.	Adjustment of cooler performance.....	44
8.	Operation and maintenance	45
8.1.	Dampers	45
8.2.	Filters.....	46
8.3.	Heat exchangers.....	46
8.3.1.	Water heater	46
8.3.2.	Electric Heater	47
8.3.3.	Water cooler.....	47
8.3.4.	Freon cooler and heater	47
8.3.5.	Rotary exchanger.....	47
8.3.6.	Counter flow heat exchanger	48

8.4. Silencer section	48
8.5. Fan unit.....	48
8.5.1. Fans	48
9. Safety instructions.....	50
10. Information	51
11. Technical information to the regulation (U) No 327/2011 Implementing directive 2009/125/EC	52

1. Introduction

ATTENTION: Warnings, Cautions and Notices appear throughout this document. Read it carefully:



-  **WARNING!** Indicates a potentially hazardous situation which, if not avoided, could result in death or serious injury.
-  **CAUTION!** Indicates a potentially hazardous situation which, if not avoided, could result in minor or moderate injury. It could also be used to alert against unsafe practices.
-  **NOTICE !** Indicates a situation that could result in equipment or property–damage only.

In-depth familiarization with the content of this manual, assembly and operation of the air-handling unit in line with the instructions provided and obeying all safety regulations constitute the basis of efficient, safe and non-failure operation of the device.

Works related to unloading packages with AHUs, transportation of the packages, connecting AHU-to the related systems as well as maintenance and repair are carried out by qualified specialists or they are supervised by authorized staff.

The **qualified technical personnel** is understood as the trained specialists, who due to the professional experience, knowledge of the subject-related standards, documentation and regulations concerning operation and safety procedures, have been authorized to perform necessary operations and who are able to troubleshoot any potential problems.

This operation and maintenance manual does not cover all possible variants of the units configurations, examples of their assembly and installation as well as start-up, operating, repairing and maintenance. If the units are used for what they are intended, this documentation and any other materials provided with the unit contain information designed for the qualified technical personnel only.

-  **NOTICE !** *Connection of the unit sections, connection of related systems, start-up, operation and maintenance of the device have to comply with the directives and regulations being in force in the country where the unit is installed.*
-  *Guarantee repairs can be carried out only by VTS Service Provider with appropriate certificates. It is recommended to engage VTS Authorized Service Providers for installation, start-up, maintenance and repairs of the AHU units.*
-  *This manual should always be kept handy for reference and be easily available for the servicing personnel.*

2. Application and design

The 8-size product line is designed for recuperation, cooling or/and heating load conditions of the air flow range 1200–16000 m³/h. The VENTUS air-handling units are designed for a ventilation system where an access to the rotating parts of the unit (a fan's rotor) is feasible neither from the overpressure nor sub atmospheric pressure side of the unit. The ventilation system is understood as ventilating ducts as well as e.g.: air intake and air exhaust modules in case of the units installed outdoor.

AHUs are equipped with a wide range of functional sections which offers extensive

possibilities of realizing the air treatment process in the field of such parameters as temperature (heat recovery, heat exchanger, heating: water or electric heaters, cooling: water or freon coolers), filtration, primary and secondary filters as well as noise level reduction.

The basic is the recovery heat exchanger section. The table 1 is showing the list of functions of the sections.

Table 1. Functions coding

R2 / CHEX2	Rotary / counterflow heat exchanger section (fans on one side of the rotor)
R2M / CHEX2M	Rotary / counterflow heat exchanger section with mixing chamber (fans on one side of the rotor)
R1 / CHEX1	Rotary / counterflow heat exchanger section (fans on both sides of the rotor)
F9	Filter section
HW	Water heater section
C	Cooler section
HwC	Water heater and cooler section
S	Silencer section
E	Empty section
V	Fan section
FV	Filter and fan section

3. General Information

The core of the VVS 21-150 compact units is the section with recovery heat exchanger. It consists (Fig.2) from filters (1), recovery heat exchanger (2) (rotary regenerator or counter flow plate heat exchanger) and fans (3). Fan can be integrated in one casing with heat exchanger or as a separate section connected to the base. That main section is available also with mixing chamber and with fans placed on one or both sides of recovery heat exchanger.

Depend on the AHU size and selection it can be one too ten direct driven fans. All with high efficient EC motors.

For the core can be add additional section for heating, cooling, filtering and noise reducing.

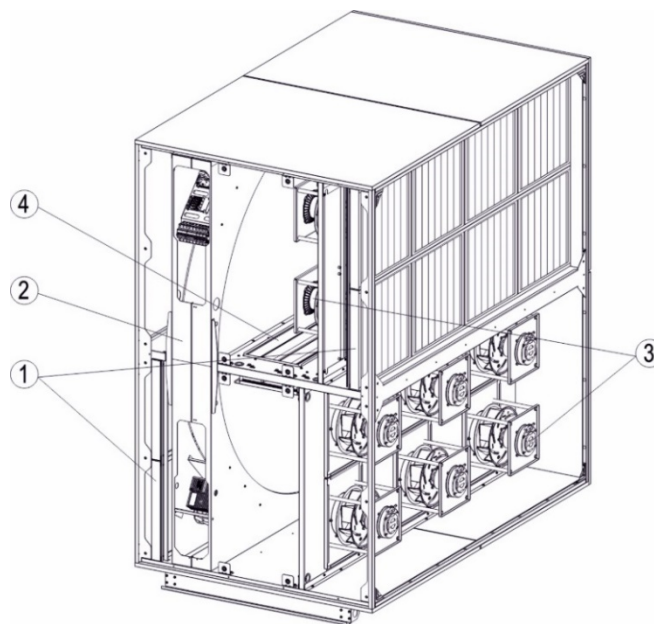
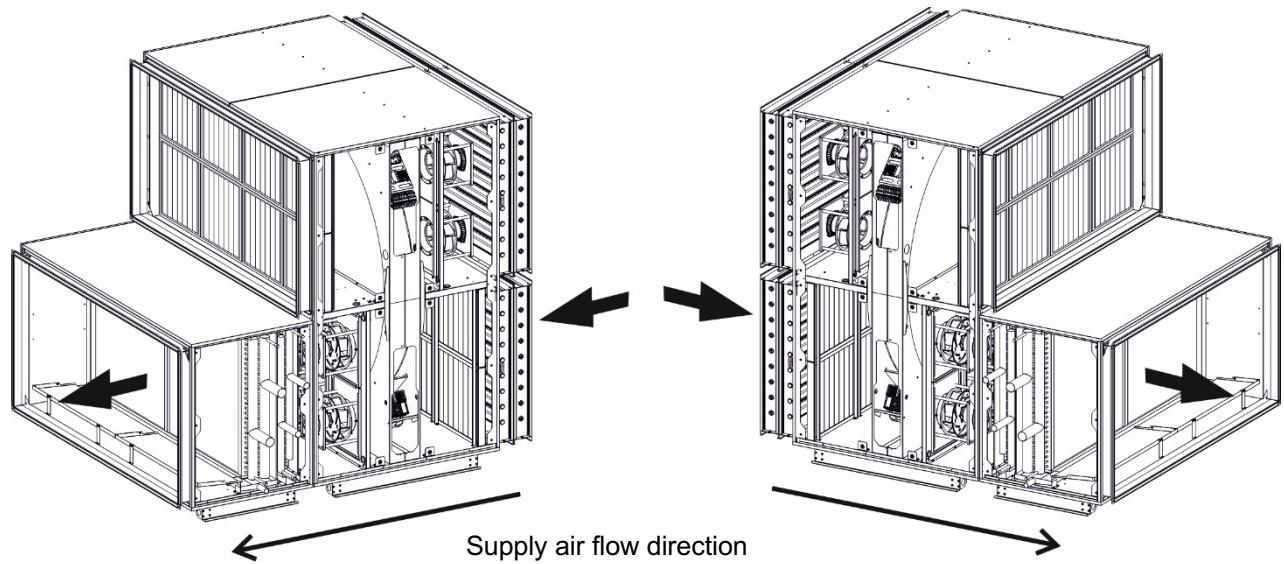

Fig.1. Example of the basic section: 1 – panel filter, 2 – rotary regenerator, 3 – direct driven fans, 4 – mixing damper

Majority of AHUs configuration is available in left-hand (LH) and right-hand (RH) version (fig. 2). The version of the unit is determined by the flow direction of the air against the tending side

of the unit (the side where the inspection panels are located). In case of supply-exhaust units the version is determined by the flow direction of the air in the supply section.



Left-hand version

Right-hand version

Fig. 2. Access side of the VVS 21-150 AHU

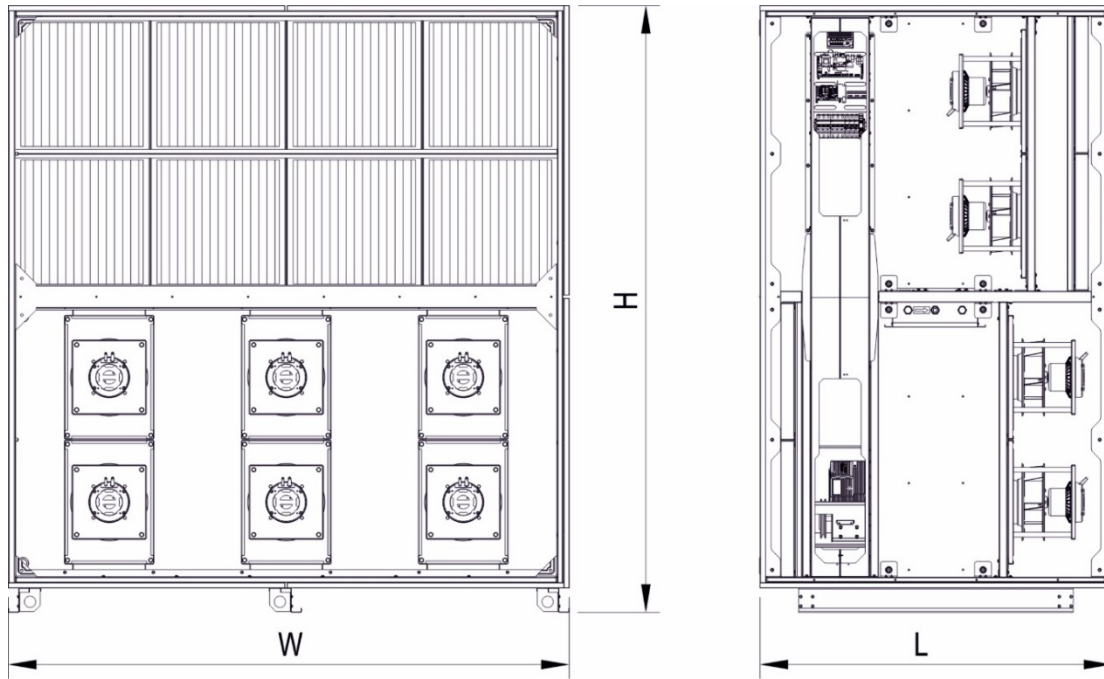

Fig. 3a. Examples of Compact AHU sections - Rotary heat exchanger section

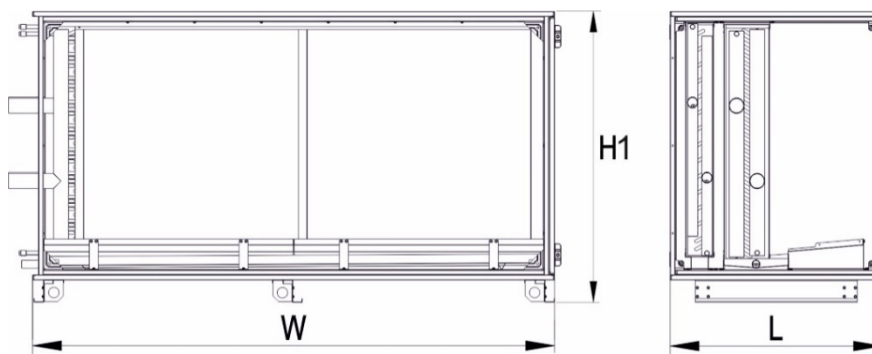

Fig. 3b. Examples of Compact AHU sections – Heater + Cooler section

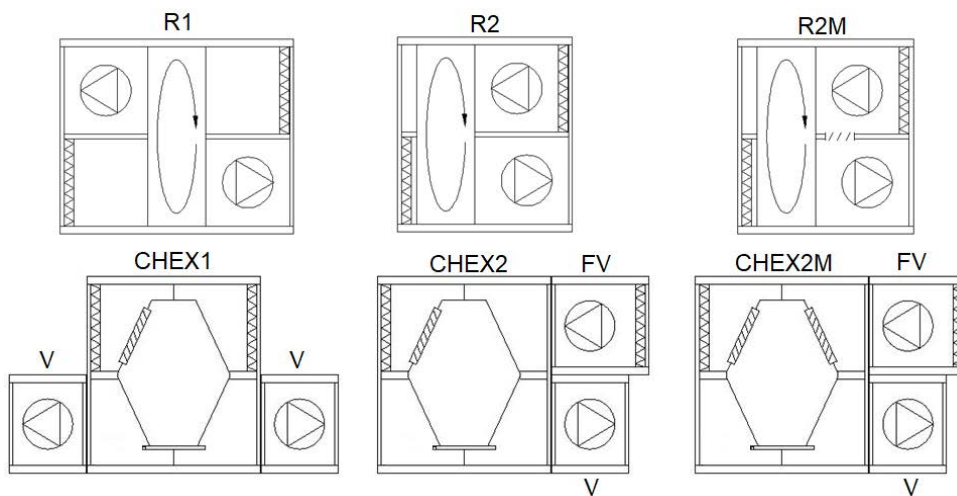

Fig. 3c. Type of the section configuration

Table 2. Functionality and dimension of the sections

AHU size	Section type		CHEX2M	CHEX2	CHEX1	R2M	R2	R1
	W	H	L					
	[mm]							
VVS021	967	901	1600	1600	1600	1080	1080	1240
VVS030	967	1165	1600	1600	1600	1080	1080	1240
VVS040	1174	1165	1600	1600	1600	1080	1080	1240
VVS055	1345	1435	1660	1660	1660	1080	1080	1240
VVS075	1486	1675	1900	1900	1900	1080	1080	1240
VVS100	1666	1875	1900	1900	1900	1300	1080	1300
VVS120	1897	1949	2000	2000	2000	1300	1080	1300
VVS150	2091	2151	2040	2040	2040	1300	1080	1300

AHU size	Section type		F9	Hw	C	HwC	S	E	V	FV
	W	H1	L							
	[mm]									
VVS021	967	448	280	280	550	550	1065	550	450	630
VVS030	967	580	280	280	550	550	1065	550	450	630
VVS040	1174	580	280	280	550	550	1065	550	450	630
VVS055	1345	715	280	280	630	630	1065	630	450	630
VVS075	1486	835	280	280	630	630	1065	630	450	630
VVS100	1666	935	280	280	830	830	1065	830	450	630
VVS120	1897	972	280	280	830	830	1065	830	450	630
VVS150	2091	1073	280	280	850	850	1065	850	450	630

4. Pre-Installation

4.1. Transport and storage

The air handling units are packaged for easy handling and storage on the job site. Upon delivery, inspect all components for possible shipping damage. See the “Receiving Checklist” section for detailed instructions. VTS recommends leaving units and accessories in their shipping packages/skids for protection and handling ease until installation.

The devices should be unloaded and transported to the AHU’s installation site using a hand lift or forklift (fig.4a) or a crane (fig.4b).

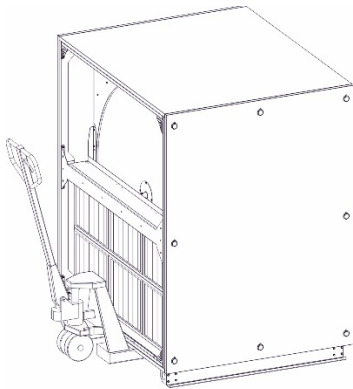

Fig. 4a. Using a hand lift to transport the unit

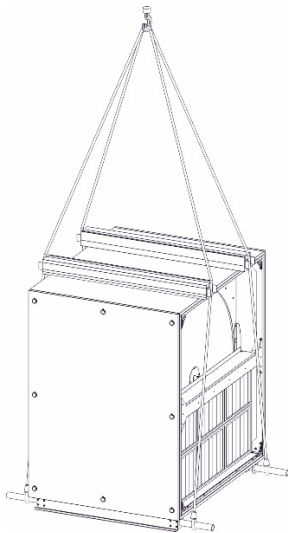

Fig. 4b. Transport with the use of a crane

The AHUs have to be transported in their working position and they shall not be stored one on the other. For transport of the units VVS 21-150 with the crane, the holes in the base frame supports can be used in order to mount an appropriate pipe bar.

The Units and its sections are intended for indoor storage. If indoor storage is not possible, VTS Company recommends the following provisions for outdoor storage:

- Place the unit(s) on a dry surface; ensure adequate air circulation beneath unit and to assure that no portion of the unit contacts standing water at any time.
- Cover the entire unit with a canvas tarp only. Do not use clear, black, or plastic tarps

The units and their components should be stored in rooms characterized by the following conditions: relative humidity: $\phi < 80 \%$ at t (temperature) = 20°C ambient temperature: $-40^{\circ}\text{C} < t < +60^{\circ}\text{C}$ – the devices should be out of the reach of any caustic dust, gas or steam as well as any other chemical substances which may have pro-corrosive influence on the unit and its components.

While storing the unit, its plastic packaging must be unsealed.

- ☑ **NOTICE!** Packages onsite must be stored on hardened, dry and protected against any precipitation place.
- ☑ Packages containing AHU elements should be stored away from places where operate mechanical devices (vehicles, cranes and other construction machinery). They should be stored in places where they will not be subject to any mechanical damages, humidity, aggressive chemical agents, fluids, dusts and other external agents which may deteriorate their condition.

4.1.1. Receiving Checklist

Complete the following checklist immediately after receiving unit shipment to detect possible shipping damage.

- Inspect individual crates before accepting. Check for rattles, bent crates corners, or other visible indications of shipping damage.
- If a unit appears damaged, inspect it immediately before accepting the shipment. Make specific notations concerning the damage on the freight bill. Do not refuse delivery.
- Inspect the unit for concealed damage before it is stored and as soon as possible after delivery. Report concealed damage to the freight line within the allotted time after delivery. Check with the carrier for their allotted time to submit a claim.
- Do not move damaged material from the receiving location. It is the receiver's responsibility to provide reasonable evidence that concealed damage did not occur after delivery.
- Do not continue unpacking the shipment if it appears damaged. Retain all internal packing, cartons, and crate. Take photos of damaged material if possible.
- Notify the carrier's terminal of the damage immediately by phone and mail. Request an immediate joint inspection of the damage by the carrier and consignee.
- Notify your VTS representative of the damage and arrange for repair. Have the carrier inspect the damage before making any repairs to the unit.
- Compare the electrical data on the unit nameplate with the ordering and shipping information to verify the correct unit is received.
- NOTICE!** *Any damages caused by improper transportation, unloading or storage are not covered by the Warrantee and any claims laid by way of aforementioned issues will not be examined by VTS.*

4.2. Installation Preparation

The Ventus Compact air-handling can be installed as well as inside the building as the outside. Units can be installed and work on the external air with temperature from -40°C to +60°C.

AHUs installed outside the building should be equipped with roof and air intake and outlet equipment. The unit operated outdoor should be regularly cleaned from the snow. Such units should have barrier for protect against the snow, and base frame should be placed on the level not lower than height of snow level in that region.

In condition of the low temperatures, increase the heat lost, what can needs more reserve of the heating capacity of the heaters. The heat node of the heating capacity regulation, three way valves, water pumps, thermo-manometers, valves, as well as frequency converters should be placed in the room with temperature higher than +5°C.

If the unit operate with the low inlet temperature of the air it is recommended to use the mixture of the glycol (up to 45%) as the heating medium. All installation pipes of the water heating, condensate drying, hydraulic valves should be well isolated. The best is use the pre-heater before the heat recovery section.

The air damper actuators should be protected from the atmospheric conditions. If the outdoor temperature is lower than -20°C, the air dampers actuators must be equipped with heating. All equipment and components operating outside the unit must have the required IP.

Units, periodically stopped during periods of low outdoor temperatures, require special attention.

They should be equipped with an automation system that supports the flow of the liquid through water heaters to prevent it from freezing during AHU downtime. If it is possible that temperature in the fan section fall below -30°C or lower, the sections should be equipped with

an internal heating system to ensure reliable start of the motors after shutdown and downtime.

4.2.1. Foundation

The unit should be placed on:

- a foundation slab
- a steel base frame concreted into the floor
- an appropriate stiff steelwork

The foundation, steel base frame or steelwork have to be flat and leveled and they should be able to support the weight of the unit.

Verify the floor or foundation is level. Repair, if necessary. Make sure proper unit operation; install the unit level (zero tolerance) in both horizontal axes. Failure to level the unit properly can result in improper operation of the unit (e.g. condensate management problems, higher vibration level, lower heating/cooling capacity).

The height of the foundation slab or base frame must allow for assembly of the siphon which drains the condensate out of the draining tray. In case of the drain plates installed in the lower AHU sections, the unit has to be mounted onto additional foundation slab or a special hollow must be made directly under the siphon. The minimum height of siphon is given in the “Draining out condensate” section.

The unit sections should be connected by the qualified personnel. Manner of the section connection is given in the “Joining of the unit section”

The section of the AHUs are equipped with frame profiles or still supports. Foundation should be prepared in the way to provide appropriate support for each base frame profiles and supports of the units. The short sections (till $L \leq 630\text{mm}$) are placed on the still supports (fig.5). The sections longer than 420mm have a base frame profiles (fig.5, 6).

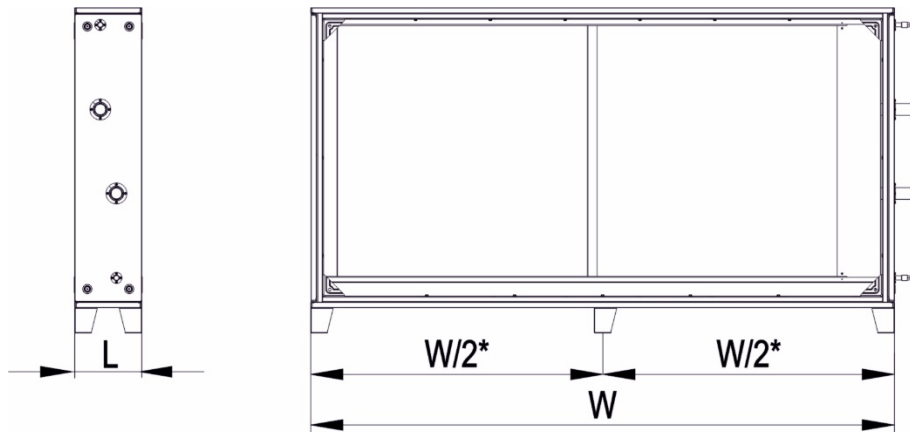

Fig.5. Supports of the short ($L \leq 630\text{mm}$) sections

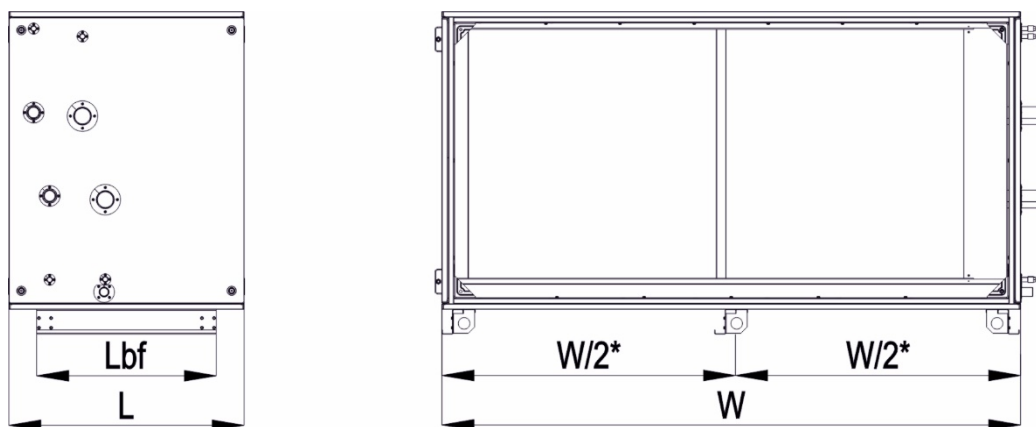

Fig.6. Base frame profiles of VVS 21-150 AHUs

*The middle profile / support exists in the units VVS 100-150

Tab.3. Relations between length of the section and length of the base frame profile

L [mm]	Lbf [mm]
650-1000	649
1040-1360	1015
1380-1600	1380
1780-1980	1746

For foundation holding of the VVS 21-150 AHUs should be drilled holes in the bottom part of the longitudinal profile of base frame.

- ☑ **NOTICE!** AHUs must be anchored to the foundation.
- ☑ **Anchoring AHUs is out of VTS delivery.**

4.2.2. Service Access

The AHU should be installed so that connections of any related systems (ventilation ducts, pipelines, cabling, etc.) do not collide with the inspection panels.

⚠ CAUTION! It is forbidden to place any elements on the AHU as well as use the AHU as a support of ventilation ducts and other building components.

In order to carry out the operation and maintenance successfully, please keep

minimum recommended distance (**fig.7**) between the front side and existing construction elements (walls, pillars, pipelines, etc.).

This is possible to install other systems, pipelines, pillars in the operation area only if they can be easily disassembled for the maintenance and service procedures.

The coils are connected on the front side of the unit

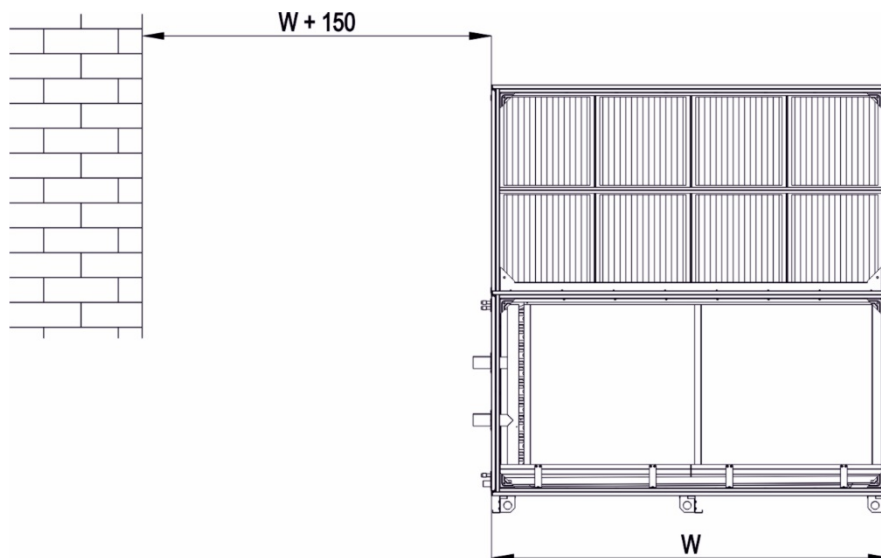

Fig.7. Free space in the front area - the VVS 21-150 AHU

4.2.3. Unit Location Recommendations

When selecting and preparing the unit installation location, consider the following recommendations.

- Consider the unit weight. Reference the unit weight on the unit nameplate
- Allow sufficient space for the recommended clearances, access panel removal, and maintenance access.

- All units must be installed level.
- Coil piping and condensate drain requirements must be considered.

Allow room for proper ductwork and electrical connections. Support all piping and ductwork independently of unit to prevent excess noise and vibration.

4.3. Joining the AHU sections and connecting the ventilation ducts

NOTICE! Joining the sections and connecting AHU to the related systems as well as maintenance and repair are carried out by qualified specialists or they are supervised by authorized staff.

To join the AHU sections one should in the first stem make sure that the base section is fixed

in the right place to the foundation. Next stick the gasket to the AHU outlet / inlet where the next section will be connected and push the additional section to the main base. (STEP 1 fig.8). Use screws delivered with the ahu and screw down according to fig.8 STEP 2 and 3.

STEP 1:

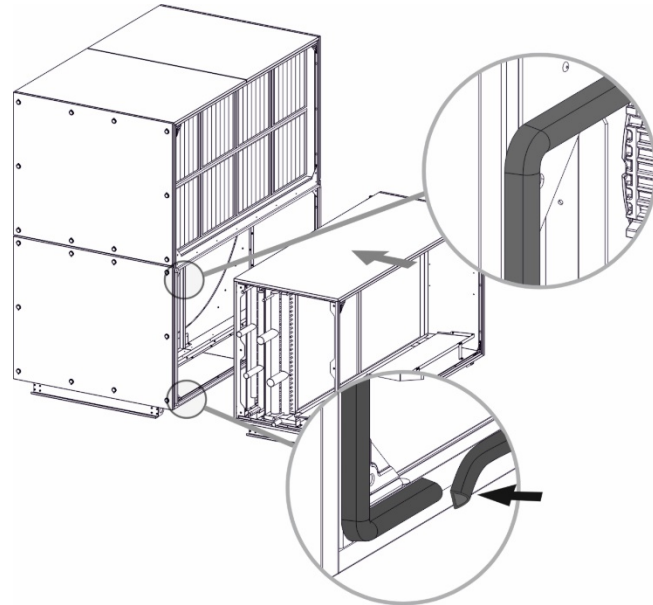

STEP 2:

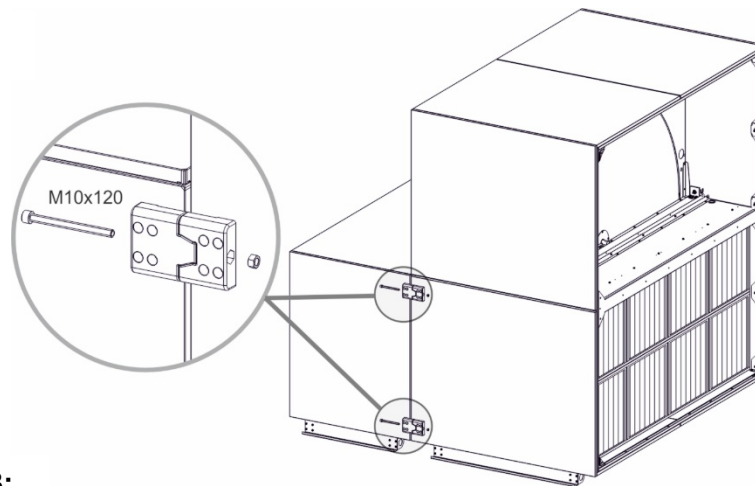

STEP 3:

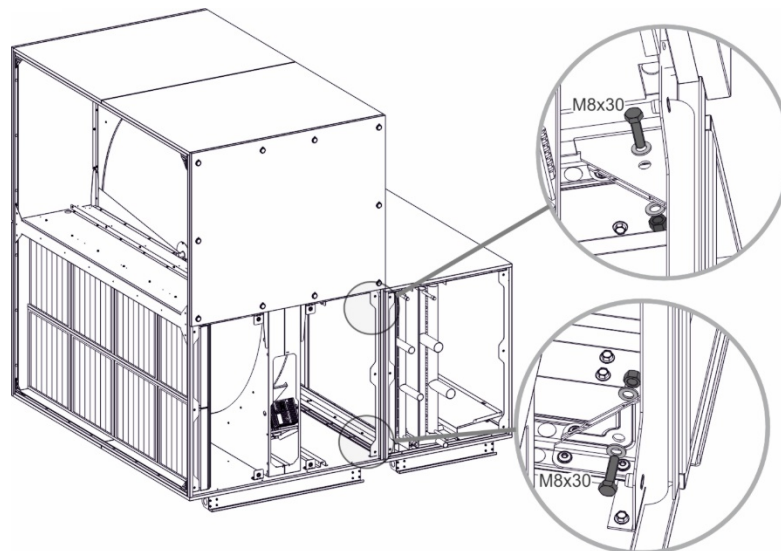

Fig.8a. Steps at the joining the AHU sections

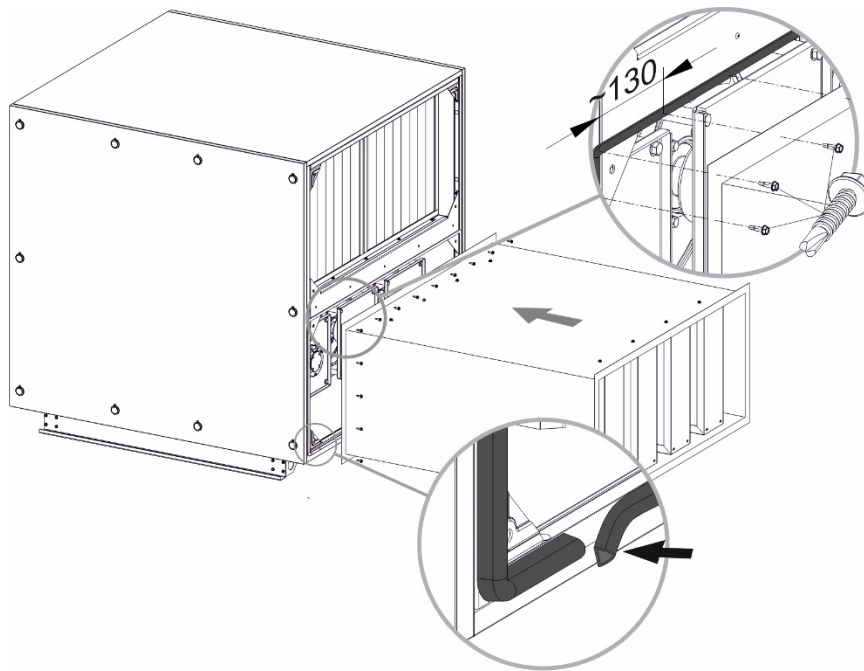

Fig.8b. Connecting the AHU sections with the duct silencer

The ventilation ducts should be connected to the AHU with the flexible connections (optional accessory) which suppress vibrations of the unit and level the coaxial deflection of the duct and the AHU outlets. Flexible connections are equipped with flanges with sealing. The flexible flanges should be connect with ducts with using drilling screws or additional clamping elements. Materials to connect ducts are not

supplied as standard delivery. Appropriate operation of the flexible connection occurs if it is stretched to about 110 mm. The ducts connected to the AHU have to be suspended or underpinned with dedicated support elements. Conducting the ducts with the fittings should be done in a way to eliminate possible increase of noise level in the ventilation system.

4.4. Connection of heaters and coolers

Connection of the exchangers should be carried out so as not to allow for stresses which may result in mechanical damages or leakage. The pipeline weight and thermal stresses cannot be passed onto the exchanger's connections. Depending on a local conditions please use the compensation at the supply and return of the pipeline system, in order to level the pipeline's linear expansion. During assembly of the supply system to the exchangers equipped with the screwed

connections, counter the exchanger's connection with additional wrench (fig.11).

The supply system should be planned so as it does not collide with the other AHU sections. Applied method of connecting the exchangers with the supply system should allow for an easy pipeline disassemble in order to remove the exchanger from the AHU, during maintenance and service operations.

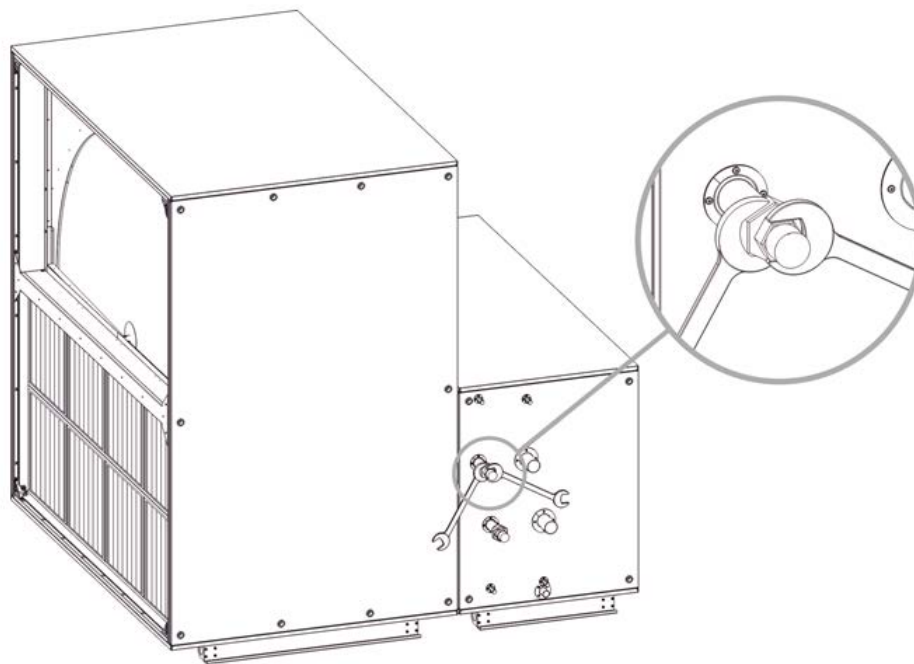

Fig.9. Securing the screwed connections of the exchanger

Supply and return exchanger connections should be connected so as the exchanger operates in a counter-current way. Stream wise

operation results in lower average temperature difference, influencing the exchanger's performance.

- ✓ **NOTICE!** Maximum operating pressure of the medium for water coils is 16 bar, tested pressure – 21 bar.

Table 4 Requirements of the quality medium for the water coils:

Parameter	Value
Oil and grease	< 1 mg/l
pH at 25°C	8 to 9
Residual water hardness	$[Ca^{2+}, Mg^{2+}]/[HCO_3^-] > 0.5$
Oxygen	< 0.1 mg/l (as low as possible)

Examples of connecting supply and return pipelines for various AHU versions shown in the picture.

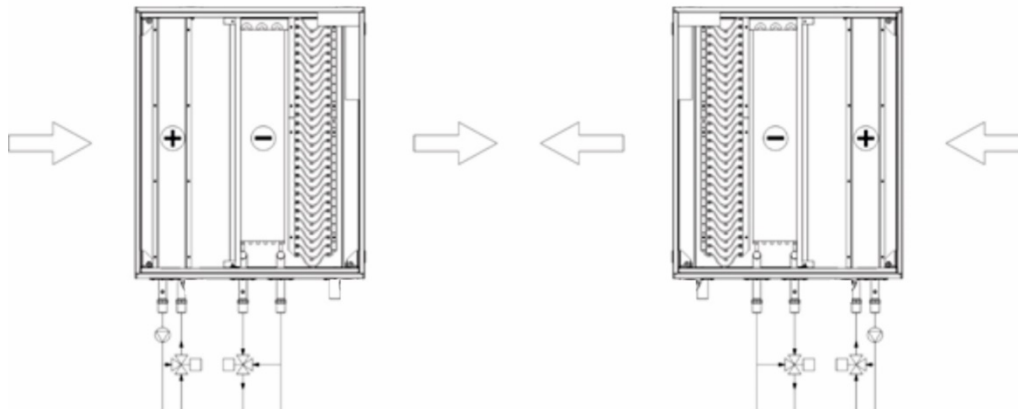

Fig.10. Examples of feeding water exchangers

Connecting the freon cooler to the supply system with a refrigerating unit should be done by a qualified cooling system specialist in

accordance with the regulations concerning the freon-driven cooling devices.

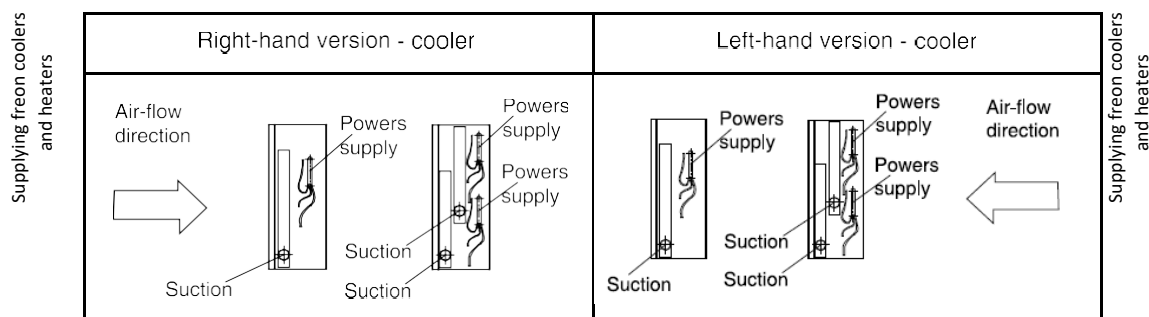

Fig. 11 Supplying freon coolers and heaters

- ☑ **NOTICE:** The DX coils have sweat connections. When brazing or welding piping: avoid exposing piping components to high heat when making sweat connections and protect the closest valve to the connection with a wet rag.
- ☑ **NOTICE:** Do not release refrigerant to the atmosphere! If adding or removing refrigerant is required, the service technician must comply with all federal, state, and local laws.
- ☑ **NOTICE:** Secure the coil against frost on the coil
- ☑ **NOTICE:** To ensure satisfactory operation of DX coolers the coolers should

be connected to the refrigerant system in accordance with all relevant regulations, rules and the best practice for that area.

4.5. Draining out condensate

The outlet condensate connections, led outside the AHU's casing are assembled in the drain plates of the cooler (the diameter of drain pan connection pipe is 32mm).

The additional section with the cooler in the compact units in majority cases will be connected to the base fan section on the pressure side. There is no need to apply drain siphons in section with overpressure, but in order to minimize air blow-by, you can use a siphon on the system draining out condensate, assembling the siphon made in accordance with fig.16a and table 8.

Siphons usable „H“ height depends on the pressure difference between the AHU section, where condensate is drained from during operation and the ambient pressure. „H“ dimension is provided in mm and must be higher than the pressure difference expressed in mmH₂O.

Siphons, which are designed to drain out

Table 5. Siphons' operational height

No.	Total fan's pressure [Pa]	Size H [mm]
1.	< 600	60
2.	600-1000	100
3.	1000-1400	140
4.	1400-1800	180
5.	1800-2200	220
6.	2200-2600	240

a)

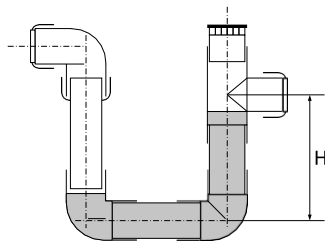

Siphon while pressing

b)

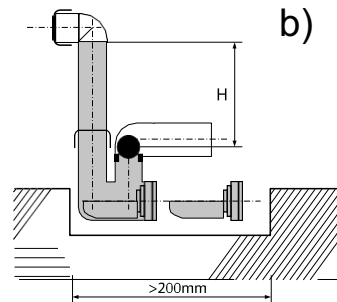

Ball siphon while sucking

condensed water from the exchangers at different pressure of the section and environment, should be connected to the drain connections.

- ⊗ **NOTICE!** Due to various pressure difference values which are present in various AHU sections during operation it is not allowable to connect several condensate outlets into one siphon.

It is allowable to join together siphons of various sections with one drain interceptor provided that the interceptor will be equipped with air-escape. Before starting the AHU, fill the siphon with water. In case of cold environment, insulate the water drain system and eventually apply suitable heating system.

Fig.12. Types of siphons

4.6. Electric connection

Connection of electric AHU elements should be carried out by qualified personnel and should be done in accordance with any standards and regulations being in force in a country where the unit is installed. Cross-section and type of cables (e.g. shielded cable) feeding individual functional segments should be selected basing on nominal current and specific operation conditions (e.g. ambient temperature, way of cabling, distance from the power supply).

VVS 21-150 compact units are delivered as completely wired. It means that all electrical elements connected with the base section like fans, rotor, actuator installed inside the section are connected to the power and control system. User should only lead the power to the AHU and connect separate control elements like

actuators, sensors, etc.

The unit with counter-flow heat exchanger is delivered as a separate sections of the exchanger and the fans. After connection the section electrical connection of the fan need to be done. See the point 4.7.4 Fan's motors.

Before starting connecting power supply, check conformity of the voltage and frequency of a supply network with the data shown on the device's rating plate. Permissible fluctuation of the supply voltage and its frequency to the values shown on the rating plate is $\pm 5\%$. If discrepancy exists, the device cannot be connected.

Details about wiring and connections is given in "Automation" section.

4.7. AHU components

4.7.1. Hydronic coil exchangers

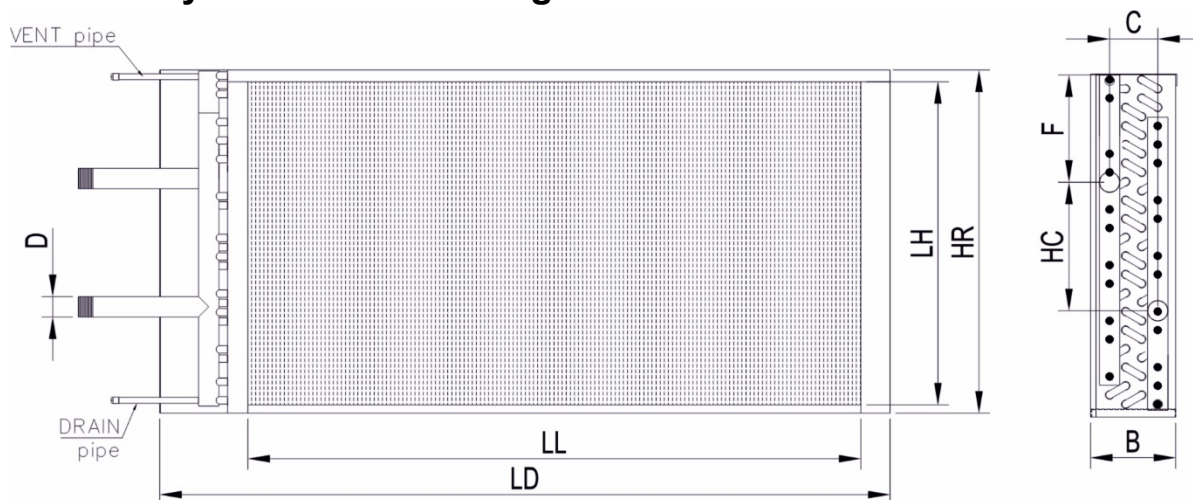

Fig. 13 Dimensions of hydronic coil exchangers

Table 6 Dimensions of hydronic coil exchangers

VS code	LL	LD	LH	HR	C	B	HC	F	D	d	weight	volume
	[mm]								inch		[kg]	[dm3]
VVS 21 WCL 1	710	873	318	321	50	112	150	86	1"	1/4"	6	1
VVS 21 WCL 2	710	873	318	321	50	112	150	86	1"	1/4"	7	2
VVS 21 WCL 3	710	873	318	321	83	147	150	86	1"	1/4"	8	2
VVS 21 WCL 4	710	873	318	321	83	147	150	86	1"	1/4"	10	3
VVS 21 WCL 6	710	873	318	321	138	192	150	86	1"	1/4"	13	4
VVS 21 WCL 8	710	873	318	321	193	252	150	86	1"	1/4"	15	5
VVS 30 WCL 1	710	873	445	448	50	112	150	149	1"	1/4"	7	1
VVS 30 WCL 2	710	873	445	448	50	112	150	149	1"	1/4"	8	2
VVS 30 WCL 3	710	873	445	448	83	147	150	149	1"	1/4"	10	3
VVS 30 WCL 4	710	873	445	448	83	147	150	149	1"	1/4"	12	4
VVS 30 WCL 6	710	873	445	448	138	217	150	149	1 1/4"	1/4"	17	6
VVS 30 WCL 8	710	873	445	448	193	252	150	149	1 1/4"	1/4"	21	8
VVS 40 WCL 1	930	1080	445	448	50	112	150	149	1"	1/4"	8	2
VVS 40 WCL 2	930	1080	445	448	50	112	150	149	1"	1/4"	10	3
VVS 40 WCL 3	930	1080	445	448	83	147	150	149	1"	1/4"	12	4
VVS 40 WCL 4	930	1080	445	448	83	147	150	149	1"	1/4"	15	5
VVS 40 WCL 6	930	1080	445	448	138	217	150	149	1 1/4"	1/4"	21	8
VVS 40 WCL 8	930	1080	445	448	193	252	150	149	1 1/4"	1/4"	26	10
VVS 55 WCL 1	1050	1251	572	587	50	112	260	164	1 1/4"	1/4"	11	3
VVS 55 WCL 2	1050	1251	572	587	50	112	260	164	1 1/4"	1/4"	14	5
VVS 55 WCL 3	1050	1251	572	587	83	147	260	164	1 1/4"	1/4"	18	6
VVS 55 WCL 4	1050	1251	572	587	83	147	260	164	1 1/4"	1/4"	22	8
VVS 55 WCL 6	1050	1251	572	587	138	217	260	164	2"	1/4"	33	13
VVS 55 WCL 8	1050	1251	572	587	193	287	260	164	2"	1/4"	14	17
VVS 75 WCL 1	1190	1392	699	702	50	112	260	221	1 1/4"	1/4"	18	4
VVS 75 WCL 2	1190	1392	699	702	50	112	260	221	1 1/4"	1/4"	23	6
VVS 75 WCL 3	1190	1392	699	702	83	147	260	221	1 1/4"	1/4"	28	9
VVS 75 WCL 4	1190	1392	699	702	83	147	260	221	1 1/4"	1/4"	43	11
VVS 75 WCL 6	1190	1392	699	702	83	182	260	221	2"	1/4"	53	18
VVS 75 WCL 8	1190	1392	699	702	138	287	260	221	2"	1/4"	14	23
VVS 100 WCL 1	1370	1572	794	806	50	112	260	273	1 1/4"	1/4"	17	5
VVS 100 WCL 2	1370	1572	794	806	50	112	260	273	1 1/4"	1/4"	22	8
VVS 100 WCL 3	1370	1572	794	806	83	182	260	273	2"	1/4"	35	13
VVS 100 WCL 4	1370	1572	794	806	83	182	260	273	2"	1/4"	41	16
VVS 100 WCL 6	1370	1572	794	806	138	217	260	273	2"	1/4"	53	23
VVS 100 WCL 8	1370	1572	794	806	138	287	260	273	3"	1/4"	76	34
VVS 120 WCL 1	1600	1802	826	838	50	112	260	289	1 1/4"	1/4"	19	5
VVS 120 WCL 2	1600	1802	826	838	50	112	260	289	1 1/4"	1/4"	25	9
VVS 120 WCL 3	1600	1802	826	838	83	182	260	289	2"	1/4"	39	15
VVS 120 WCL 4	1600	1802	826	838	83	182	260	289	2"	1/4"	47	19
VVS 120 WCL 6	1600	1802	826	838	138	252	260	289	3"	1/4"	71	32
VVS 120 WCL 8	1600	1802	826	838	138	287	260	289	3"	1/4"	87	39
VVS 150 WCL 1	1790	1997	921	937	50	112	260	339	1 1/4"	1/4"	22	7
VVS 150 WCL 2	1790	1997	921	937	50	112	260	339	1 1/4"	1/4"	30	11
VVS 150 WCL 3	1790	1997	921	937	83	182	260	339	2"	1/4"	46	18
VVS 150 WCL 4	1790	1997	921	937	83	182	260	339	2"	1/4"	56	23
VVS 150 WCL 6	1790	1997	921	937	138	252	260	339	3"	1/4"	85	38
VVS 150 WCL 8	1790	1997	921	937	138	287	260	339	3"	1/4"	105	48

4.7.2. DX coils

One-circuit (One-section) DX coils

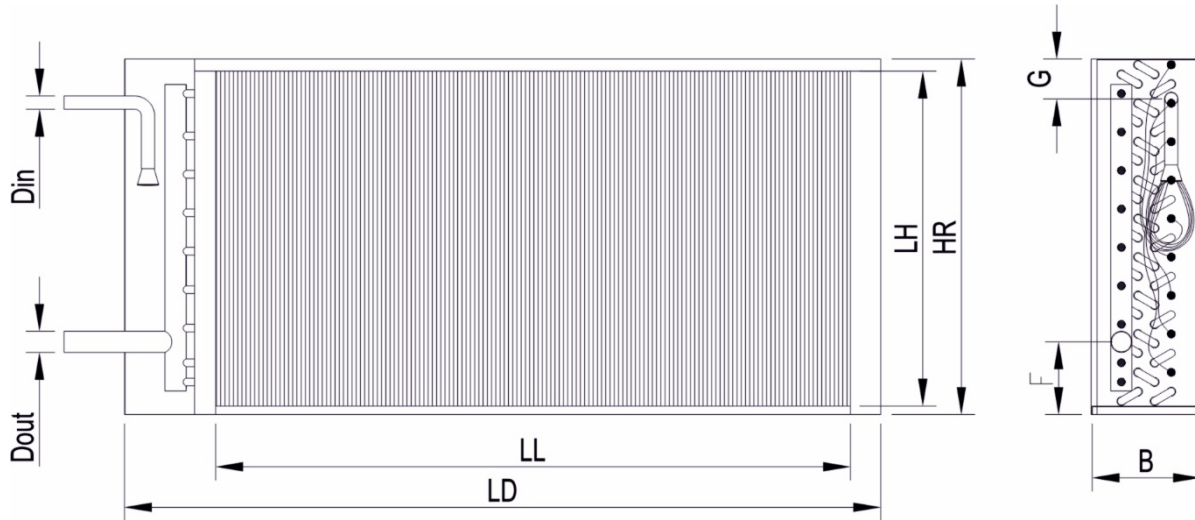

Fig. 24 One-circuit (One-section) DX coil

Table 7 Dimensions of one-circuit (one-section) DX coils

Ventus code	LL	LD	LH	HR	TR	D	E	F	G	ØD In	ØD out	Weight	Coil volume
	[mm]											[kg]	[l]
VVS 21 DX 2-1.	710	873	318	321	110	41	91	79	13	16	28	7,7	1,8
VVS 21 DX 3-1.	710	873	318	321	145	45	120	79	13	16	28	12,7	3,5
VVS 21 DX 4-1.	710	873	318	321	180	49	131	79	13	16	28	17,6	5,3
VVS 21 DX 6-1.	710	873	318	321	250	56	194	79	26	22	28	22,6	7,1
VVS 30 DX 2-1.	710	873	445	448	110	41	91	77	45	16	28	9,7	2,5
VVS 30 DX 3-1.	710	873	445	448	145	45	120	77	45	16	28	16,1	5,0
VVS 30 DX 4-1.	710	873	445	448	180	49	131	77	65	16	28	22,8	7,4
VVS 30 DX 6-1.	710	873	445	448	250	56	194	77	52	22	28	29,2	9,9
VVS 40 DX 2-1.	930	1080	445	448	110	41	91	77	41	22	35	11,8	3,3
VVS 40 DX 3-1.	930	1080	445	448	145	45	120	77	45	16	28	20,1	6,5
VVS 40 DX 4-1.	930	1080	445	448	180	49	131	77	41	22	35	28,2	9,7
VVS 40 DX 6-1.	930	1080	445	448	250	56	194	77	54	22	35	36,4	13,0
VVS 55 DX 2-1.	1050	1251	572	587	110	41	91	120	84	22	28	16,9	4,7
VVS 55 DX 3-1.	1050	1251	572	587	145	45	120	120	98	22	35	26,8	9,4
VVS 55 DX 4-1.	1050	1251	572	587	180	49	131	120	66	22	35	46,8	14,1
VVS 55 DX 6-1.	1050	1251	572	587	250	56	194	120	55	22	42	56,7	18,9
VVS 75 DX 2-1.	1190	1392	699	702	110	41	91	118	63	16	28	21,4	6,5
VVS 75 DX 3-1.	1190	1392	699	702	145	45	120	118	116	22	28	34,9	13,1
VVS 75 DX 4-1.	1190	1392	699	702	180	49	131	118	159	22	35	59,9	19,6
VVS 75 DX 6-1.	1190	1392	699	702	250	56	194	118	97	22	42	73,4	26,1
VVS 100 DX 2-1.	1370	1572	974	806	110	41	91	120	87	22	28	26,3	8,5
VVS 100 DX 3-1.	1370	1572	974	806	145	45	120	120	87	22	35	55,0	17,1
VVS 100 DX 4-1.	1370	1572	974	806	180	49	131	120	113	22	42	73,7	25,6
VVS 120 DX 2-1.	1600	1802	826	838	145	59	118	120	102	22	35	30,7	10,4
VVS 120 DX 3-1.	1600	1802	826	838	145	45	120	120	125	22	42	63,3	20,7
VVS 120 DX 4-1.	1600	1802	826	838	180	49	131	120	125	22	42	97,1	31,1
VVS 150 DX 2-1.	1780	1997	921	937	145	59	118	120	91	22	35	36,5	12,9
VVS 150 DX 3-1.	1780	1997	921	937	180	63	143	120	78	22	42	74,8	25,7
VVS 150 DX 4-1.	1780	1997	921	937	215	66	164	120	123	22	54	114,4	38,6

Two-circuit (Two-section) DX coils

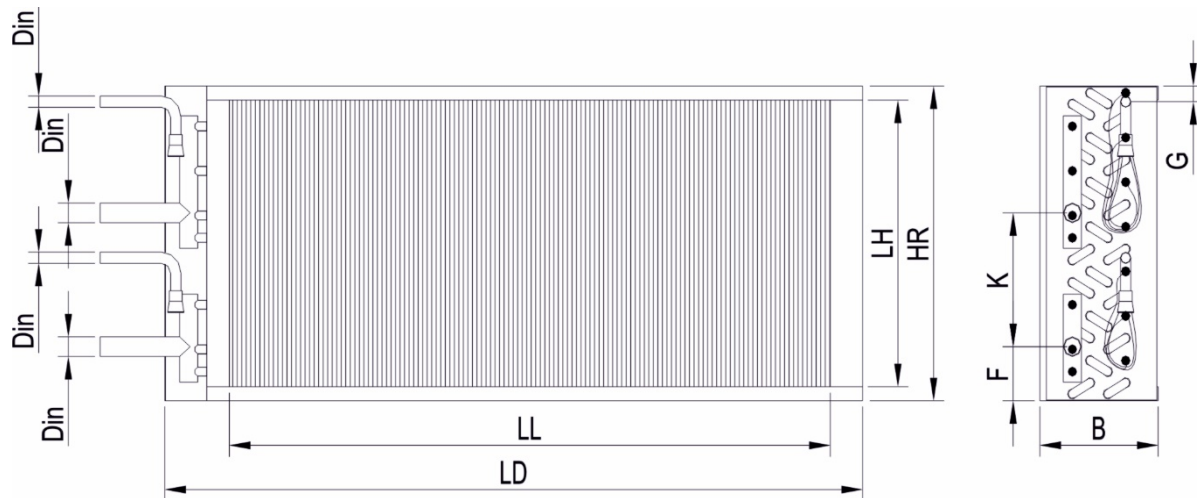

Fig. 35 Two-circuit (Two-section) DX coil

Table 8 Dimensions of two-circuit (two-section) DX coils

Ventus code	LL	LD	LH	HR	TR	D	E	F	G	K	ØD In	ØD out	Weight	Coil volume
	[mm]											[kg]	[l]	
VVS 30 DX 6-2.	710	873	446	448	250	56	194	80	25	219	2x16	2x28	22,2	7,4
VVS 40 DX 4-2.	930	1080	445	448	180	49	131	77	22	191	2x17	2x28	19,6	6,5
VVS 40 DX 6-2.	930	1080	445	448	250	56	194	77	22	191	2x18	2x28	27,5	9,7
VVS 55 DX 3-2.	1050	1251	572	587	145	45	100	120	25	254	2x19	2x28	21,3	7,1
VVS 55 DX 4-2.	1050	1251	572	587	180	49	131	120	38	222	2x20	2x28	26,2	9,4
VVS 55 DX 6-2.	1050	1251	572	587	250	56	194	120	19	254	2x22	2x35	45,6	21,2
VVS 75 DX 3-2.	1190	1392	699	702	145	45	100	118	76	318	2x16	2x28	27,4	9,8
VVS 75 DX 4-2.	1190	1392	699	702	180	49	131	118	19	318	2x16	2x28	34,0	13,1
VVS 75 DX 6-2.	1190	1392	699	702	250	56	194	118	58	349	2x22	2x28	58,4	29,4
VVS 100 DX 2-2.	1370	1572	974	806	110	41	91	120	57	381	2x16	2x28	25,7	8,5
VVS 100 DX 3-2.	1370	1572	974	806	145	45	100	120	50	349	2x16	2x28	40,2	12,8
VVS 100 DX 4-2.	1370	1572	974	806	180	49	131	120	49	381	2x22	2x28	53,6	17,1
VVS 100 DX 6-2.	1370	1572	974	806	250	56	194	120	42	381	2x22	2x35	71,9	25,6
VVS 120 DX 2-2.	1600	1802	826	838	110	41	91	120	73	381	2x16	2x28	30,0	10,4
VVS 120 DX 3-2.	1600	1802	826	838	145	45	100	120	35	381	2x16	2x28	46,6	15,6
VVS 120 DX 4-2.	1600	1802	826	838	180	49	131	120	35	381	2x22	2x28	61,7	20,7
VVS 120 DX 6-2.	1600	1802	826	838	250	56	194	120	19	381	2x22	2x35	94,6	31,1
VVS 150 DX 2-2.	1780	1997	921	937	110	41	91	120	107	381	2x16	2x28	35,6	12,9
VVS 150 DX 3-2.	1780	1997	921	937	145	45	100	120	49	445	2x22	2x35	55,1	19,3
VVS 150 DX 4-2.	1780	1997	921	937	180	49	131	120	69	445	2x22	2x35	72,9	25,7
VVS 150 DX 6-2.	1780	1997	921	937	250	56	194	120	59	445	2x22	2x42	111,6	38,6

4.7.3. Electric heater

Connecting power supply to the heater with control module should be done directly in the heater section, according to the guidelines of the module operation and maintenance manual. In any other case connecting power supply should be carried out with a separate switchgear, not supplied with the VTS package. Each heating unit of the heater is connected separately to the terminal strip, which is located sideways of the heating subassembly casing.

Connection of the heater should be done in a way to prevent from possibility of switching on the heater when the fan is not switched on. What is more, if the fan stops, the heater's power supply must be turned off as well. Depending on the automatics system, the heater's power can be adjusted smoothly or gradually. In order to control the heater gradually.

☉ **NOTICE!** The thermostat must be absolutely installed in the heater control system.

Thermostat functionality is based on the bimetal element properties, resulting in opening the heater control circuit contacts at air temperature near the thermostat up to 65°C. After emergency turn off, the heater turns on automatically once the air temperature goes down by 20°C. After intended or emergency (caused by overheating) turning off the power supply, the supply-air fan has to operate for some time (0.5–5 min), so as the heater's coils reached their normal temperature.



1. Overheating thermostat



- a) Functions and application
 - Protection module of the electric heater protecting it against overheating
- b) Construction
 - Metal casing
 - Two screw terminals
 - bimetallic element with a function of a normally closed contact
- c) Operation parameters
 - activation temperature: 65±3°C
 - hysteresis: 17±3°C
 - parameters of bimetallic element voltage: 30VDC permissible load.

- a) Functions and application
 - Fan's pile-up control
- b) Construction
 - Membrane coupled with mechanical module. If the acceptable pressures difference is exceeded, the membrane undergoes deformation and switches off
 - casing: plastic
- c) Operation parameters
 - measurement: 20 – 300 Pa:
 - rated operational voltage 30VDC
 - output signal: voltage-free (switching contact)
 - number of cycles: 10^6 cycles
 - operation conditions: -30 – +85°C
 - protection class: IP44

Recommended pressure control operating position: horizontal. In case of vertical alignment, the set point value is 11Pa higher than the real one.

2. Differential pressure control

4.7.4. Fan's motors

The fan of the VVS 21-150 compact units are integrated with EC motors.

AHU can be equipped with 1 to 10 fans on the one side of the unit.

Table 9 Fan size configuration

AHU size	Fan size configuration				
21	2x225	1x250	-	-	-
30	3x225	2x225	-	-	-
40	3x225	2x250	-	-	-
55	4x225	3x225	2x225	-	-
75	5x250	4x250	3x250	2x250	-
100	6x250	5x250	4x250	3x250	-
120	7x250	6x250	5x250	4x250	-
150	10x250	9x250	8x250	7x250	6x250

IP protection class of the motors with the controller is 44. The own electronics protect them against the overload, phase fail/lose, under and over voltage and phase over current.

The motor can be started by means of digital commands, bus commands references or local start command whenever the drive is connected to the AC line.

The base AHU section is completely cabled with full automation control if that option ordered.

If the fans are delivered as a separate section it needs to be electrical connected to base (heat exchanger) section.

Fig.16a shows description of the fan terminal. Prepared cable in the heat exchanger section are marked in the same way.

Fig.16b shows description of the molex cables.

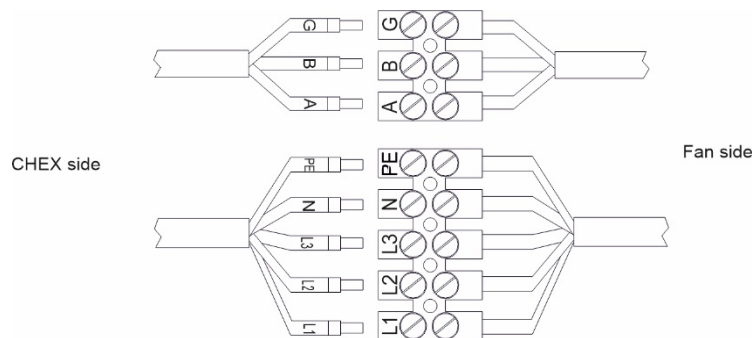

Fig.16a. Fan electrical terminals

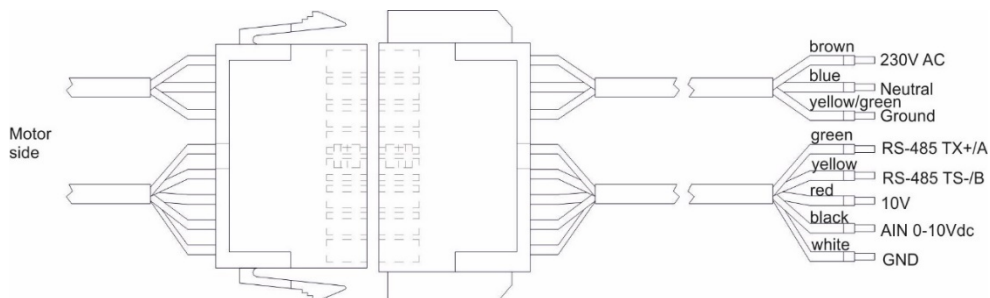
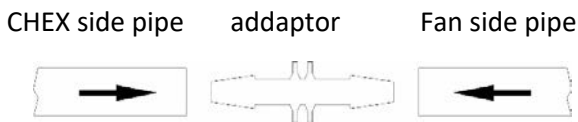

Fig.16b. EC motor cable description

If full automation option orders, besides the electric, pneumatic connection must be done. The sections are equipped with pressure pipes for control pressure drop on the filter and fan. Pipes must be connected with using special adaptor:



For section V (fan) are 2 pipes, for FV section (filter and fan) are 4 pipes. Adaptor should be fixed in the support on the fan diaphragm.

4.7.5. Air Filters

Pleated panel filters in three filtration classes respectively.

Table 10 Panel filters sizes

AHU size	Size	Amount	Filtration class
	WxHxC [mm]	pcs	
VVS021	440x361x48	2	M5 F7 F9
VVS030	440x493x48	2	
VVS040	543x493x48	2	
VVS055	463x370x48	6	
VVS075	463x370x48	6	
VVS100	523x419x48	6	
VVS120	600x438x48	6	
VVS150	496x489x48	8	

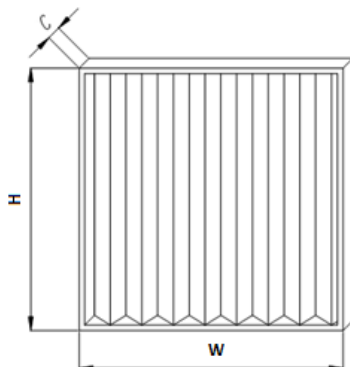

4.7.6. Rotary heat exchanger

Rotary regenerator together with fan sets and filters creates a base section. The rotor is driven with EC motor reducer. Drive of the rotor is completely cabled and configured.

Any change in configuration of the rotary exchange drive unit can be done by Authorized VTS Service.

4.7.7. Counter-flow heat exchanger

The high efficiency counter-flow flow heat exchanger inbuilt in the AHU casing as a separate section. Unit is completely cabled with full automation control and cable prepared to connect the fans.

5. Automation

5.1. Description of controls

5.1.1. Introduction

Application:

Protection and control of supply and exhaust AHUs equipped with up to:

- two fan and two air dampers
- cooler, heater, heat recovery system

Range of operation: VVS021c–150c

Systems equipped with EC motors

5.1.2. Mains switch

Function: Switching the control gear

On



Off



5.1.3. Communication port



RJ11 – socket, is placed in front of the control gear housing

Function:

Connecting the HMI Advanced UPC control panel to the controller.

5.1.4. Signaling controller status



In the bottom left side of the controller, there are two LED indicators.

Orange LED indicates the condition of the power supply. LED off means no power supplied to the terminals or malfunction of internal power supply circuitry. LED on means correct parameters of the power supply.

Green LED indicates the condition of controller's BIOS. LED off means that the firmware is not running correctly. LED on means that BIOS runs OK and the controller is ready for operation.

- 1) All control gears need to be powered from the main switchgear equipped with appropriate protection of wires powering the control box.
- 2) Assembly, wiring and start-up of the control gear should be done by qualified staff only.
- 3) For applications subject to strong vibrations (1.5 mm pk-pk 10/55 Hz), secure the cables connected to the μ PC using clamps placed around 3 cm from the connectors.
- 4) The entire length of the input/output connections must be less than 30 m, according to EN 61000-6-2.
- 5) Installation must be performed according to the standards and legislation in force in the country where the appliance is used.
- 6) In the event of malfunctions do not attempt to repair the controller, but rather contact the service.

The control gears it is not adapted to outdoor work without additional elements.



LCD Display

Displaying available parameters, settings and current values

BELL Button Jump to alarm handling pages

PRG Button

- 1) Quick jump to the Calendar main page
- 2) In Calendar pages – quick clear of the settings

ESC Button

Jump to the main page or leaving the parameter change

UP Arrow

- 1) Moving up across the menu screens (when the cursor stays in upper left corner)
- 2) Increasing the parameter value

ENTER Button

- 1) Moving the cursor across the screen – cursor jumps to the next parameter available for changing. Read-Only parameters are not marked with the cursor.
- 2) Confirming entered values
- 3) Entering sub-menus from the main menu level:
 - Parameters
 - Calendar
 - Alarms
 - Settings
 - Service

DOWN Arrow

- 1) Moving down across the menu screens (when the cursor stays in upper left corner)
- 2) Decreasing the parameter value

Navigation example:

- 1) In the main menu level use UP/DOWN arrows to find the desired sub-menu

- 2) Press ENTER to go to the sub-menu level
- 3) Use UP/DOWN arrows to move across the sub-menu screens
- 4) In the desired screen, use the ENTER button to switch between the changeable parameters – the cursor starts from the upper left corner (which is the base position) and jumps on and on until going back to the upper left corner – then the loop can be started again
- 5) To change the parameter marked with the cursor, use the UP/DOWN arrows
- 6) Press ENTER to go confirm the change and to jump further

Functions:

- Air handling unit operation, parameterization and maintenance
- Selection of control application
- Time zones setting
- Displaying and canceling alarm statuses, viewing alarm history

Note!

Parameters available in the LCD window depends on AHU type and the control application. Hence in AHUs not equipped with heater, options related to the heating module will not be visible.

HMI Advanced UPC can't serve as a room temperature sensor.

5.1.5. Simplified control panel – HMI Basic UPC



1) LCD Display

Indicates actual room temperature or temperature on the main control sensor as well as a chosen setting, operation mode, fan speed, time and day of the week.

2) ON/OFF button

Switching between On/Off state (forcing the unit to stop or enabling operating mode selection)

3) Fan button

Button for mode setting: Auto / Low / Econo / Comfort

4) Clock button

Entering Auto mode. Controller will operate according to the time schedule stored in Calendar settings.

Note!

There are two options for time schedule operation. For details, follow manual for uPC3.

Note!

If the Calendar is also in Auto mode, the AHU operation will rely only on protective and energy saving functions like Standby and Night Cooling. This is possible for the main Calendar of the controller. The built-in Calendar of the HMI Basic doesn't support that functionality.

5) Push & Roll knob

Quick, intuitive and easy entering values, changing set points, accepting new values.

Note!

To change the temperature set point, just turn the knob.

Display of the room sensor temperature or the value of the temperature set point offset

Note! Setting is limited to 16...26°C

- Icons for active recirculation, cooling or heating
- Time indication
- Display of the fan speed setting or the indication of automatic fan mode
- Indications of the weekdays
- Icon for active recovery unit
- Icon for alarm event
- Icon for Off mode

Functions:

- Room temperature measurement and display
- Change and display of temperature set point
- Change and display of fan set point

- Display temperature of the main control sensor
- Change of AHU operation mode
- Info on alarm status

Optional element. Connects to the controller via the Modbus line, common with the frequency converters.

Web-Server / Modbus TCP/IP Option – Available as Expansion Card

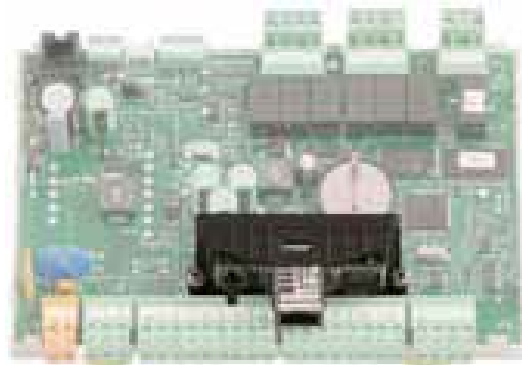

Gives extended access to read / write parameters like measurement readouts, set points, settings, output values, selected calendar settings, alarms. Total count of available parameters exceeds 200 data points.

SEE SPECIAL MANUAL FOR DETAILS OF EXPANSION CARD OPERATION

5.2. System Start-Up

Operation of the AHU is strictly arrested by the fire-protection alarm, activation of the thermal protection of fans' motors, threefold activation of the protection of electric heater and threefold activation of the anti-frost thermostat. Each of these events requires removing the cause of the alarm and then canceling it (see more details in Advanced Manual).

5.2.1. Switching on power supply

Switching on power supply of the control gear with the mains switch (Q1M). Correct power supply and good BIOS operation is indicated by yellow and green LED lamps on the controller's PCB.

The system is ready for operation after about half minute from switching on.

Note!

If the system did not start, check the F5 protection on power box status correct device operation depends on the application settings. Choosing and setting up the application should be done by qualified service provider, according to recommendations of part II "Advanced manual".

5.2.2.HMI Advanced UPC



Main menu structure

- 1) Main default screen with most important statuses and set points.
 - Set mode HMI** – is used to set the main operating mode from the HMI.
 - Current mode** – indicates current AHU mode resulting from HMI setting, alarms, external control signals etc.
 - Set temp HMI** – is used to enter the main temperature set point from the HMI.
 - Current temp** – temperature readout from the main sensor.
- 2) Second main status screen
 - Fans** – indicates the current state and rate of the fans
 - Dampers** – indicates the current state and opening rate of the dampers
 - Regulator** – indicates the state and the output of the main controller for heating / cooling function
 - Recovery** – indicates the state and rate of the heat recovery unit
 - EN/PL/RU** – language selection
 - PASSWORD** – is used to enter to special settings and hidden parameters
- 3) Sub–menu link screen
 - PARAMETERS** – link to main statuses and readouts from the control system
- 4) Sub–menu link screen

- CALENDAR** – link to calendar settings and time schedule programming
- 5) Sub–menu link screen
- ALARMS** – link to alarm pages
- 6) Sub–menu link screen
- SETTINGS** – link to set and adjust the control system, regulators, timers
- 7) Sub–menu link screen
- SERVICE MENU** – link to main configuration parameters, application codes, AHU startup settings

All the menus are dynamically changed, as they depend on the application settings

5.2.3.Selection of operating mode

The AHU can operate in one of the following operating modes.

- **Auto – AHU operates depending on** – the calendar programming
 - HMI Basic**
external control signals (binary inputs) critical temperatures, e.g. too low temperature causes AHU start and immediate heat–up of the room.
 - **Off – AHU switched off** – fans stopped, dampers and control valves closed all sensors and gauges are activated – in order to protect the unit from damage, e.g. fire alarm, Frost protections.
 - **ECO – Lower economy mode** – The fan speed and the dead zone for temperature regulation are adjustable. The temperature control algorithm can use broad dead zone and the fans can be set to low speed in order to reduce energy consumption.
 - **Optimal – Upper economy mode** – The fan speed and the dead zone for temperature regulation are adjustable. The temperature control algorithm can use narrower dead zone and the fans can be set to higher speed in order to optimize energy consumption.
 - **Comfort – Comfort mode** – The fan speed and the dead zone for temperature regulation are adjustable.

The temperature control algorithm can use most accurate dead zone and the fans can be set to highest speed in order to give maximum comfort.

Note!

The temperature set point is common for all operating modes, the dead zone settings are individual for each mode.

HMI ADVANCED

Selection path: Main menu / Set mode HMI / Auto / Off / Low / Econo / Comfort

HMI ADVANCED

Set mode HMI	Comfort
Current mode	InitHtg
Set temp HMI	21,0°C
Current temp	19,4°C
Mon 28.02.2011 10:09	

HMI BASIC

- 1) On/Off button – press to switch between Off and Low mode.
- 2) Fan button – press to switch operating mode between Low – Econo – Comfort
- 3) Clock button – press shortly to switch to Auto mode. In Auto mode Calendar will be capable of taking over the control.



5.2.4. Indication of operating mode

The following modes can be displayed in Current mode field in the main menu: Auto / Off / Low / Econo / Comfort as described above

- **Fire** – operating mode enabled by fire alarm input. All the devices switched off, the fans stop or run with selected set point (see chapter Service Menu)
- **OverRun** – AHU switches off, but the fans keep running on the idle speed until the heater is cooled down (see chapter Service Menu)
- **NightClg** – Night Cooling – a mode for energy saving by cooling down the room using cold air from the outside in the night. Available only in the units with external temperature sensor.

- **Standby** – protection mode for min/max room temperature – if the temperature exceeds specified set points, AHU is switched on, to heat up or cool down to desired range. Then switches off again.
- **NightKick** – testing mode that forces fans to run in order to exchange the air in the ventilation system.

Note!

Night cooling and Standby functions rely on room temperature. If there's no measurement in the room, the exhaust duct sensor is taken into account and gives the readout. This requires turning on the fans to have appropriate room temperature value on that sensor.

- **InitHtg** – Initial Heating – a mode for startup of water heating units in winter conditions, heats up the coil before starting the fans in order to prevent activation of frost alarms.
- **Startup** – temporary mode when dampers are opening, fans speed up and the heating / cooling devices are enabled and start operation.
- **FastHtg / FastClg** – Fast Heating or Cooling – special mode for units with PCR or RRG recovery, that allows operation with closed intake/outlet dampers and full recirculation. That improves heating up the building.
- **Heating** – mode when heaters can be enabled
- **Cooling** – mode when coolers can be enabled
- **Vent** – Ventilation – energy saving mode, when neither heaters nor coolers are enabled and the unit operates only with ventilation and optional recovery unit.
- **EmgStop** – Emergency Stop – unit forced to stop immediately, according to signal from optional digital input.
- **AlrStop** – Alarm Stop – unit forced to stop because of an alarm
- **CrtStop** – Critical Stop – unit forced to stop because of a critical alarm
- **Config** – unit forced to stop because the controller is in Config mode. Controller must be configured first and switched to Running mode

The unit can be controlled from several sources. Mind the priorities between them.

- 1) HMI Advanced (highest priority)
- 2) The BMS over Modbus TCP/IP connection
- 3) External control inputs
- 4) HMI Basic
- 5) The calendar mode

Note!

To enable another sources than the HMI Advanced, the Operating mode HMI must be set to Auto

5.3. Technical data

5.3.1. Operation parameters

System	TN
U3 rated power supply voltage	~230V
Ui rated insulation voltage	400 V
Uimp rated impulse withstand voltage	2.5 Kv
rated short-time withstand current I _{sc} for respective circuits – effective value of alternating current component withstood during 1 second, i.e.: short-circuit current expected at rated connecting voltage	6 kA
rated peak withstand current (ipk) at cosφ= 0.5	10.2 kA
rated short-circuit current	6 kA
coincidence factor	0.9
rated frequency	50 Hz ± 1Hz
protection class	IP40
acceptable operating temperature	-20 ÷ 40 °C
supply voltage of control circuits	24 V AC
EMC environment	1

5.3.2. Carel µPC controller

RESOURCES

Relay outputs Q1..Q7

Analog inputs B1..B6	Reference GND;	potential
Outputs, DC 0–10V (1mA)	Reference GND;	potential
Binary inputs DI1..DI6	Voltage free contacts Reference GND;	potential
Analog outputs Y1..Y3	0...10V, max 5mA Reference GND;	potential
RS485 communication port (J10)	Modbus 1200m	protocol,

Optional expansion card for Ethernet communication	RJ45 socket
	10/100 MBit (IEEE 802.3U)
	Capable of: Parameter overview via Internet browser Modbus TCP/IP Server functionality via port 502 (data points specified by the end of that manual)
HMI Advanced comm. port (J7 or J8)	Serial link over RS485 connection Standard connection – factory supplied flat cable, 3m long



5.3.3. Cabling

Connect power leads of the control gear and frequency converter of the fan drive according to the Electric diagram.

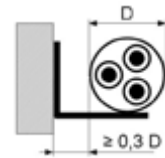



By default, Compact type AHUs have internal wiring. For motors, a fan diaphragm is equipped with a connection box on the inspection side. Power supply and ModBUS communication cables are connected to the junction box. VTS automation communicates with motors via the ModBUS RTU protocol. If it is necessary to use other automation and use the 0-10V DC signal, the user must change the cabling. A description of the pins available in this junction box is provided in the table below:

connector marking	wire colour	function
L1	brown / black / gray	power supply – phase 1
L2		power supply – phase 2
L3		power supply – phase 3
N	blue	power supply – neutral
PE	green – yellow	power supply – ground
A	green	ModBUS - RX+
B	yellow	ModBUS – RX-
G	white	ModBUS - ground

The wire cross-sections have been selected for long term current capacity for cables arranged in the air (supported on brackets, cable racks, in perforated trays) with spacing from the wall of min. 0.3 cable diameter, insulated with PVC, for 3-conductors loaded.

Due to the protection selectivity, length, cable placement method and short-circuit currents, revise the feeders' cross-sections in the table below.

Wire type	Wire picture	Wire description	Parameters
[1]		Control wires with copper	Nominal voltage: 300/500 V

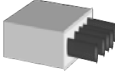
		cores with a shield. PVC isolation.	Ambient temperature: – 30 to 80°C
[2]		Copper cores. PVC isolation.	Nominal voltage: 450/750V Ambient temperature: from –40 to 70°C
[3]		Copper cores. PVC isolation.	Nominal voltage: 150 V Ambient temperature: – 20...60°C
[4]		Flat communication cable without shield.	Nominal voltage: 150V Ambient temperature: – 20...60°C

Name of element / connection point	Symbol	Wire type	Name of element / connection point
Controller	N1	–	–
Fire alarm switch	S1F	[2]	2x0,5
Multi-function switch	S6	[2]	2x0,5
Optional multi-function switch	S7	[2]	2x0,5
Supply air temperature sensor	B1	[1]	2x0,5
Room/ Return air temperature sensor	B2	[1]	2x0,5
External air temperature sensor	B3	[1]	2x0,5
HW back-water temperature sensor	B7	[1]	2x0,5
HE alarm switch	VTS–E–005 ter. 22:23	[2]	2x0,5
HW anti-frost air side thermostat	S2F	[2]	2x0,5
HW analog controlled valve	Y1	[1]	3x0,5
CW analog controlled valve	Y2	[1]	3x0,5
HE power rate control input	VTS–E–005 ter. 15:21	[1]	3x0,5
HW circulating pump contactor	M1		3x1,5
CW analog controlled valve	Y2	[1]	3x0,5
Chiller / refrigerating unit / heat pump alarm switch	S5F	[2]	2x0,75
Chiller start input	E1	[2]	2x0,75

Refrigerating unit start input – I stage	E2.1	[2]	2x0,75
Refrigerating unit start input – II stage	E2.2	[2]	2x0,75
Recirculation damper actuator	Y3	[1]	3x0,75
Cross-flow bypass actuator	Y4	[1]	3x0,75
AHU alarm	E4	[2]	2x0,75
HMI Basic UPC – reduced function interface	N2	[3]	UTP 1x2
HMI Advanced UPC – full function interface	N3	[4]	8x0,1

Supply elements

Intake damper actuator	1Y1	[2]	2x0,75 / 3x0,75
------------------------	-----	-----	-----------------

Exhaust elements

Redundant damper actuator – exhaust	2Y1	[2]	3x0,75
-------------------------------------	-----	-----	--------

Supply Cabling for units:

Unit size	Supply cable	3x400V AC
VVS021c	5x2,5 mm ²	
VVS030c	5x2,5 mm ²	
VVS040c	5x2,5 mm ²	
VVS055c	5x4,0 mm ²	
VVS075c	5x4,0 mm ²	
VVS100c	5x6,0 mm ²	
VVS120c	5x6,0 mm ²	
VVS150c	5x10 mm ²	

5.4. Connection

5.4.1. Standard connection

The device in the standard version has full internal wiring. Equipment of the device:

- B2 – Temperature sensor – return
- H2 – Humidity sensor – return
- B4 – Temperature sensor – return after recovery
- B9 – Temperature sensor – supply after recovery
- 1S1H - Pressure control –primary filter, supply
- 1S3H - Pressure control – supply fan
- 2S1H - Pressure control – primary filter, supply
- 2S3H - Pressure control – return fan

Connected supply fan, return fan and sensor.

5.4.2. Power connection

From the user's side, the power supply and the main disconnector and external

peripherals remain connected to Terminal 1

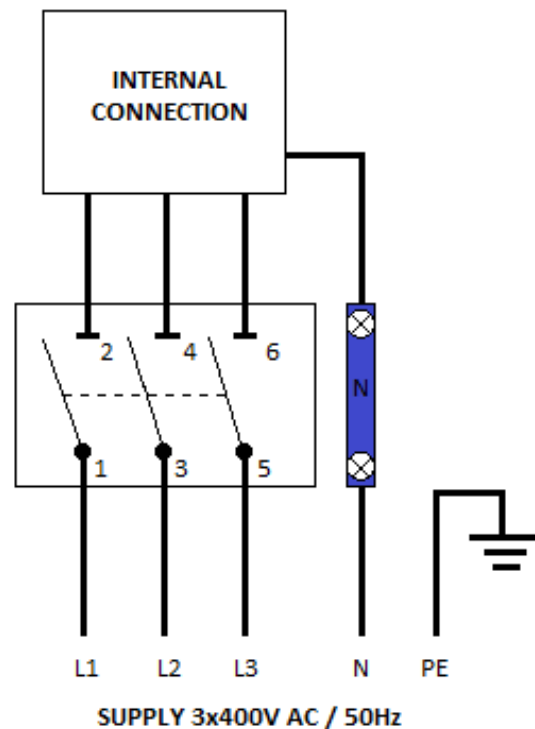

Power supply connection for circulation pump for the water heater, connector 1, N, PE at the main disconnector.

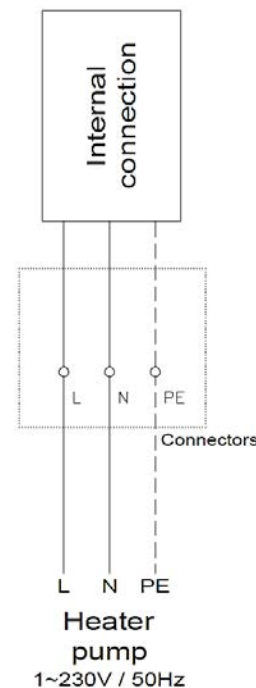

5.4.3. Connection of automation elements

Terminal 1

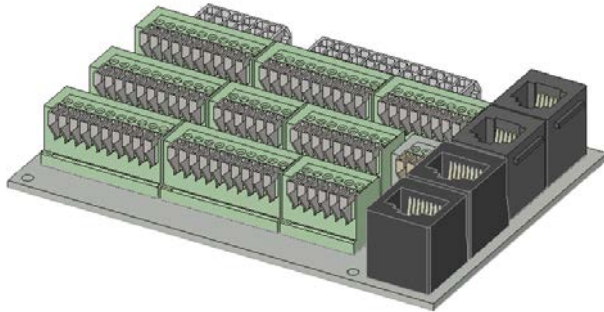

Analog input (NTC10k)

- B1 – Temperature sensor – supply
- B2 – Temperature sensor – return
- B3 – Temperature sensor – outside
- B7 – Temperature sensor – heater



Terminal connection – HMI Advance (N3)

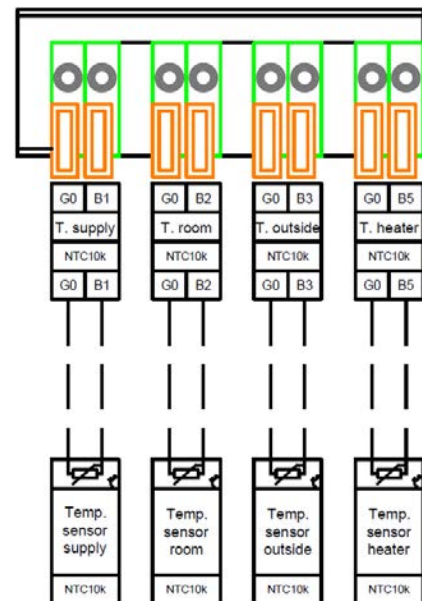
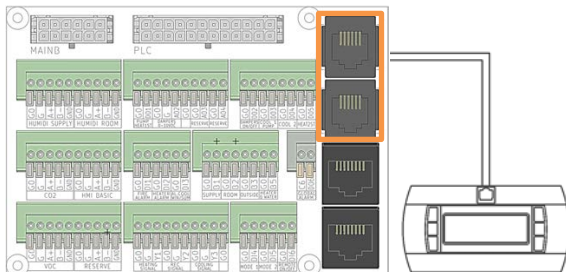

Analog output (0–10V DC)

- Y1 - Heating
- Y2 - Recovery
- Y3 - Cooling
- AO2 - Mixing damper

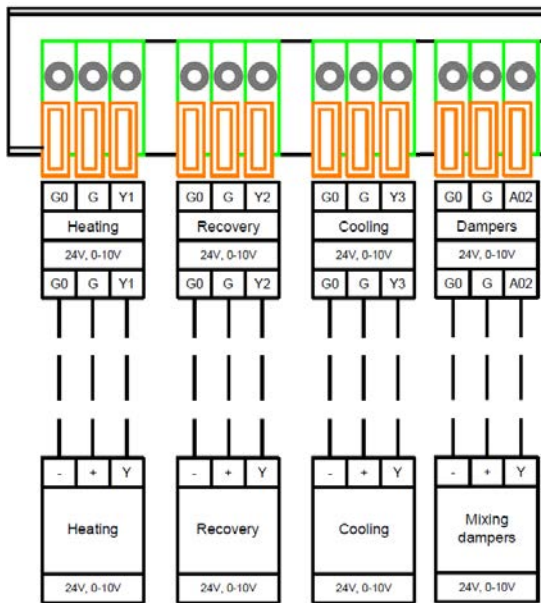

Digital output (24V DC)

- 1Y1 / 2Y1 - Dampers
- M1 - Heater 1
- Heater 2
- E1/E2.1 - Cooler 1
- E2.2 - Cooler 2
- E4 - Global alarm

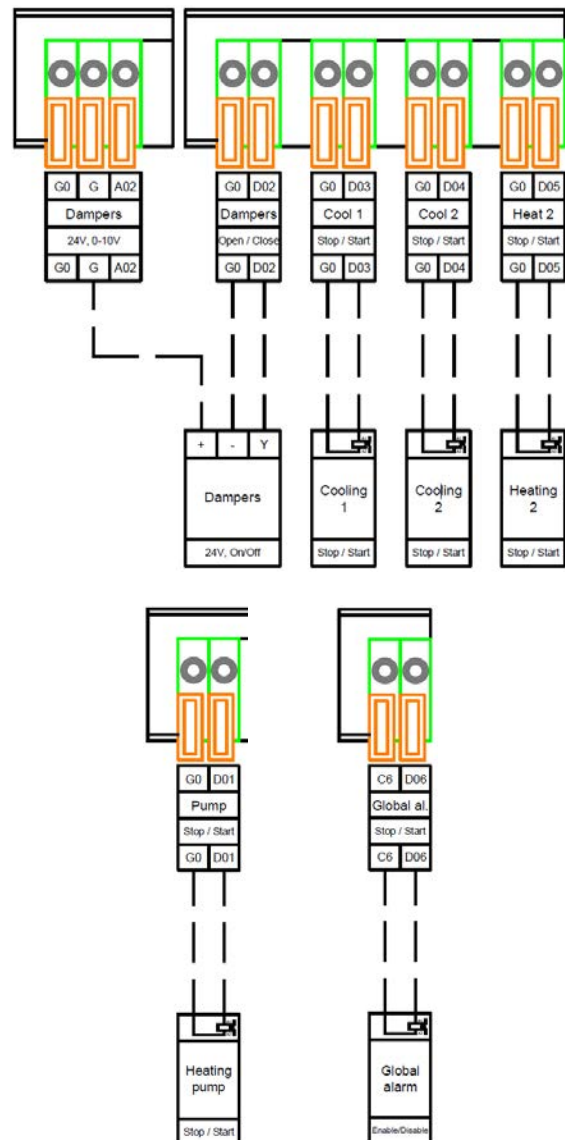

Digital input

- S1F - Fire alarm
- S2F - Heater alarm / Frost alarm
- S5F - Cooler alarm
- S6 - Mode 1
- S7 - Mode 2
- Remote



Communication Modbus RTU – RS-485

- Humidity sensor – supply
- Humidity sensor – room
- CO2 sensor
- VOC sensor
- HMI Basic

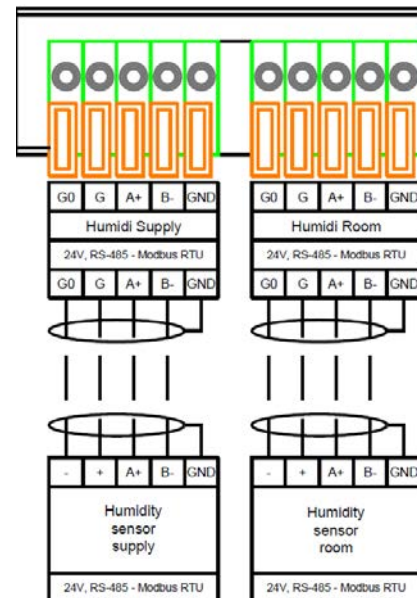
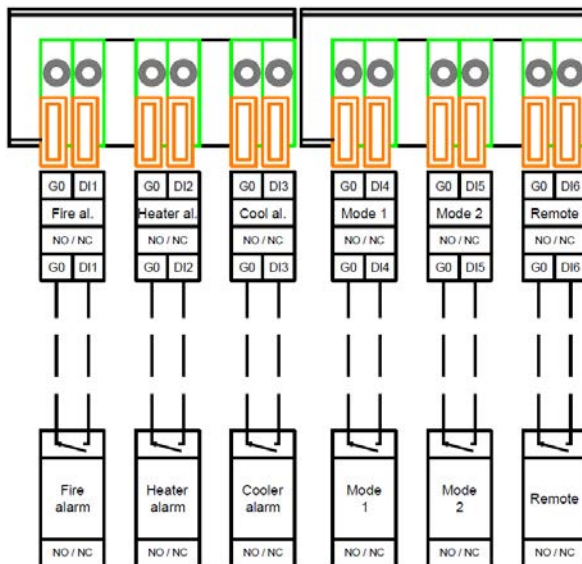

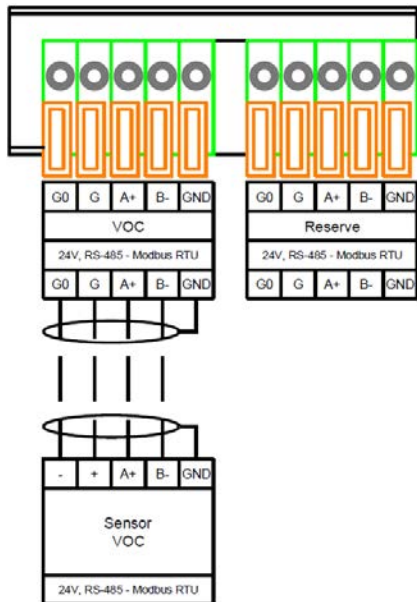
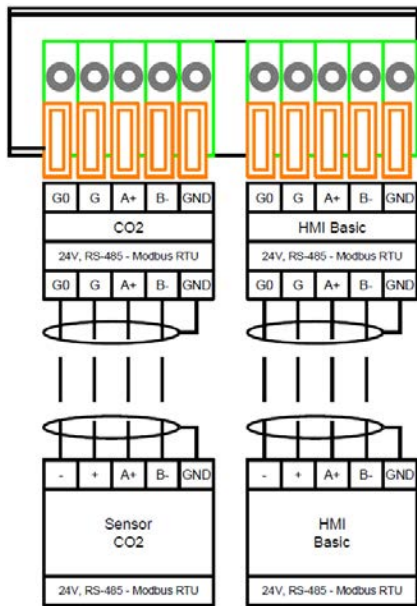

6. Preparation for start-up

AHU start-up at putting the ventilation system into service can be carried out only by qualified and competent personnel. Before starting-up the system and ducting must be thoroughly cleaned.

Check if:

- during assembly operations systems and devices' elements as well as automatics elements and equipment were not damaged,
- all ventilation devices are mechanically installed and connected to the ventilation

system,

- ground cables connecting the control gear with ventilation ducts are installed,
- hydraulic and freon systems are fully installed and ready for operation and heating or cooling medium is present during the start-up,
- all automatics elements are installed and wired,
- all unit access panels are in place and that all bolts are tightened to their proper torques.

6.1. Electrical system

Before closing connecting boxes of the electric devices check the following:

- basing on appropriate electric diagrams – conformity of connections,
- application of protection units for all electric devices,
- fastening all screws and appropriate assembly of any supporting elements and electric connections (also unused support terminals – if any),
- cables and wiring – for conformity with all relevant safety, functional, cross-section, etc. regulations,
- appropriate ground and protection systems,
- inside of connecting boxes – if there are no loose or redundant cables left,
- condition of sealings and sealing surfaces.
-

- ☑ **NOTICE!** The AHU can only be operated with assembled filters.

Before closing the filtration section please make sure to:

- remove protective foil from filters,
- assemble filters in their slideways so as the bag were in vertical position,
- check filters' condition and leaktightness of fitting in the slideways,
- check settings of differential pressure controls (if they are applied) which determine permissible static pressure difference qualifying a filter for replacement.

6.2. Filters

Air filters in AHU prevent from getting dust into ventilated rooms. And what is more, they protect other AHU functional elements (e.g.: heat exchangers) against contamination.

- ☑ **NOTICE!** The AHU can only be operated with assembled filters.

Before closing the filtration section please make sure to:

- remove protective foil from filters,

- assemble filters in their slideways so as the bag were in vertical position,
- check filters' condition and leaktightness of fitting in the slideways,

Table 11. Permissible pressure difference

Filter type and class	Permissible pressure difference	
B.FLT	M 5	200 Pa
	F 7	200 Pa
	F 9	300 Pa

6.3. Water heaters

Check the following:

- connection of supply and return pipelines,
- if the anti-frost thermostat's capillary is firmly attached to the heater's casing,
- setting of the anti-frost thermostat (factory setting: +5°C),
- if heater's control valve has been installed in accordance with markings shown on its casing.
- water heater need antifrost thermostat.

6.4. Electric heaters

Check the following:

- electric connections, in accordance with electric diagrams for heaters' connection,
- connection of the protection thermostat,
- if the heating units do not touch other elements within the heating section,
- if the heaters' heating units are not damaged.

6.5. Water coolers, freon coolers and heaters

As in case of water heaters, check the following:

- condition of the cooler's lamellas,
- connection of supply and return pipelines,
- condenser position towards the air-flow direction,
- assembly of the siphon - fill it with water before starting the AHU up,
- passability of the condensate drainage system.

6.6. Rotary exchanger

Before starting up the exchanger, check the following:

- if the cleaning air-lock is installed on the side of the supply-air duct,
- once the drive belt is assembled and the exchanger is turned on, make sure that direction of rotor's rotations led from exhaust-air ducts, through the cleaning air-lock and to the supply-air ducts (fig. 22)
- rotor rotates freely. Sensible resistance can be caused by too excessive hold down of sealing brushes and touching the rotor's edges. In such a situation adjust the brushes properly

6.7. Counter-flow heat exchangers

Check the following:

- condition of exchanger's lamellas (contamination, mechanical damages),
- assembly of the siphon – fill it with water before starting the AHU up,

6.8. Fan unit

Check if:

- there are no objects within a range of the fan, which might be sucked into the rotor once the fan is turned on,
- the fan's rotor rotates freely, without any friction against the casing elements,
- the fan's rotor rotates freely and does not touch the stator,
- all screws, supporting elements and electric connections are fasten firmly,
- supply cables located inside the fan section are far from any loose drive elements and

they are fasten with appropriate clamps to the electric wiring,

- the rotor rotation direction is the same as a direction of the arrow placed on the fan's wheel (switch on the fan by pulsing).

Once the aforementioned control activities are performed, close carefully all AHU's inspection panels.

⚠ CAUTION! Operation of the device with open inspection panels is forbidden.

7. Start-up and adjustment

The start-up is going to test if the AHU is made in accordance with the design and is ready for operation.

Start up and ventilation/air-conditioning systems adjustment can be done only by qualified and competent start-up personnel, equipped with necessary test devices.

After completing activities described in point 6 you can proceed with the first start-up. In case of AHUs equipped with secondary filtration section it is recommended to start up the system without the secondary filter insert.

After start-up check if:

- there are no suspicious noises and unnatural mechanical sounds,
- there are no considerable AHU vibrations.

The AHU should operate for about 30 minutes. After that time turn it off and inspect individual sections. Pay utmost attention to:

- filters (if they are not damaged),
- condensate drain-out,
- fan unit (belt tension, fans and motors' bearing temperature).

After starting up the AHU replace or clean the preliminary filters.

Achieving required performance of the AHU depends, among the others, on carried out adjustment and test measurements.

7.1. Measurement of air quantity and AHU output adjustment.

Measurement of air quantity is a primary measurement in case of:

- AHU start-up and technical acceptance,
- when the system does not operate in line with the requirements and expectations,
- periodic control of AHU operation and performance,
- replacement of fan unit elements.

Before starting measurements and adjustment make sure to check if damper at all air grates or registers are adjusted in line with the design.

Determining quantitative air stream is based on the measurement of average air-flow speed in the ventilation duct test cross-section. One of the most common ways of determining average speed is the cross-section probing method with the Prandtl pipe and measurement of the speed-related average dynamic pressure.

Crucial factors influencing the measurement accuracy are:

- location of the measured cross-section in relation to the elements,
- quantity and location of test points in the measured cross-section,
- stable and constant air flow.

It is highly recommended NOT to locate the measurement cross-section directly after network elements causing deformation of velocity speed (knees, reductions, three-way connections, dampers, etc.), fan, because in the cross-section some reverse speed may appear.

The measurement should be carried out at the duct's fragment with parallel walls and straight segments at least 6 times longer than the duct diameter or equivalent diameters before the test point and not less than 3 diameters after it. In the real ventilation system finding such a long straight fragment can be a problem. In such a case determine the measurement cross-section in a place where the smallest distortions of air-flow are expected and intensify a network of test points. Location of the measurement cross-section should be determined on the system design stage. Detailed recommendations concerning air-flow measurement and location of test points are defined by the ISO 5221 standard.

We estimate the output being measured as sufficient unless it differs more than $\pm 10\%$ from the designed one. In case of bigger disproportions, the output alike the designed one can be achieved by:

- adjustment of the ventilation ducts network,
- changing adjustment of the main damper,
- changing the fan rotary speed.

7.2. Heat output adjustment of water heater

Heater output adjustment is proceeded by setting appropriate amount of air passing through the AHU.

Heater output adjustment consists in checking the heater's performance from the air's side through temperature measurements in front and behind the heater, at designed supply and return temperature values and amount of heating medium in the system.

Heater's output is controlled by adjustment of water supply temperature. It is achieved by mixing up in the three- way valve supply water with high temperature and water coming back from the heater, with lower temperature. Once mixed, water getting to the heater reaches appropriate temperature - depending on the mixing level.

External conditions, similar to the rated ones occur within an annual cycle during relatively short period. In most cases you have to take into consideration the fact that the adjustment must be carried out in intermediate conditions, which must be recalculated in order to conform to the rated values.

Checking operation of the anti-frost thermostat is possible only when temperature of air supplied onto the exchanger is lower than the thermostat setting (factory setting: +5°C). It is safe to carry out this activity when the supply air temperature is 1-2 degree above 0°C. Then, when the AHU is running, cut for a moment the inflow of heating medium and watch if the thermostat is triggered. This operation should be carried out before putting the AHU into service.

7.3. Adjustment of electric heater

Power adjustment of electric heater is carried out in most cases by means of turning off individual group of heating coils. Multistage control (table.8) is carried out through connecting specific heating coils with each other. Smooth control of heater power is carried out by applying the VTS control module.

Perform simulation of lower power requirement by decreasing the set temperature value so as all electric steps (contactors) were in off position. Next increase significantly the setting and check if all electric steps turn on in the order in accordance with the operation description. Restore the previous temperature setting.

Also check operation of overheating protection in case of lack of air-flow. To do so, reduce the air-flow stream flowing through the heater by pushing to the inlet damper or by reducing the fan's speed.

- ☑ **NOTICE!** During AHU operation speed of air flowing through the heater should not be lower than 1.5 m/sec.

Please note that the lower air-flow is the more possible it is to overheat the system.

Bringing AHU to a standstill must involve some delay (0.5-5 minutes), so as to cool down heating coils of the electric heater.

7.4. Adjustment of cooler performance

Adjustment of cooler performance should be carried out in conditions similar to the rated ones. As in case of the heater, the effect from the air side is considered, including temperature and humidity in front and behind the cooler.

Temperature of cooling agent is controlled this way as well. If cooler operation effect is not satisfactory, appropriate adjustment is required. It can be carried out using the following methods:

- adjustment of cooling medium amount (water

coolers),

- adjustment of air amount passing through the AHU (water cooler and coolers with direct medium evaporation),
- adjustment through changing evaporation temperature (in case of systems with direct evaporation).

Coolers operate in most cases in complex air-conditioning systems equipped with automatic control. Automatic control devices should be tested not only in extreme conditions but also in intermediate cooler load circumstances

8. Operation and maintenance

- ✓ **NOTICE!** Personnel in charge of AHU operation should read through this documentation before starting any operation and maintenance activities. When no such personnel with appropriate skills and competence is available, periodic inspections should be carried out by the authorized VTS service providers.
- ✓ Any damages of the AHU or its parts resulting from not following the guidelines stated in this documentation will not be subject to warranty claims.
- ✓ Any AHU maintenance operations should be carried out with the device turned off.

Basic AHU technical data such as type and parameters of the most significant parts (filters, heat exchangers, fans, electric motors) are provided in the Technical Data Card supplied with each device.

Thorough and regular maintenance as well as technical inspections of the AHU and its components are necessary in order to find the failures at their early stage - before more serious damages appear.

This documentation only covers general guidelines regarding control periods ensuring error-free operation of the AHU due to various possible external conditions of AHU operation.

Control periods must be adapted to local conditions (contamination, number of start-up cycles, load, etc.).

Personnel in charge of the AHU should from the first AHU start-up keep up-to-date records making use of the "Inspections and maintenance table" which is Included in the Warranty Card. Any routine works related to the AHU operations should be recorder there. Carefully kept register is the only reliable document stating the unit operation condition, dates of current inspections, identified problems, etc. In case of contact with the VTS representatives always use the AHU factory identification number, located on the casing as well as in the AHU documentation.

Duration of periods between particular actions have been determined with assumption that the AHU works "non-stop" in low-dust environment and with no other disadvantages deteriorating the operation conditions. In environments with high level of dust in supply or exhaust air, the inspections should be carried out more frequently.

AHU spare parts and accessories can be ordered at local **authorized VTS service provider**. While ordering parts please use the type and factory identification number of the device. This information can be found on the rating plate located on the fan section.

8.1. Dampers

If the damper is contaminated and does not operate freely it should be cleaned in one of the following ways:

- with industrial vacuum cleaner with soft suction nozzle,
- blow through with compressed air,
- wash with water under pressure with cleaning agents which do not cause aluminum corrosion.

The damper should be accurately sealed after re-assembly, first of all from the side of external air, otherwise the water heater can be frozen.

8.2. Filters

In standard AHU operation conditions the filters should be replaced circa each twice a year. Necessity of replacing the filter (beside the visual contamination) is also indicated by pressure drop according the data shown in Table 9.

The AHUs can be equipped with the following filters:

- P.FLT preliminary panel filters, M 5, F 7
- P.FLT secondary panel filters, F 9 class.

☑ **NOTICE!** Filtration level may vary depending on the filter type and that is why this is very important to install the same filter with the same filtration class.

8.3. Heat exchangers

8.3.1. Water heater

Operating water heaters should be equipped with anti-frost system. Optionally, in winter period replace heating medium of the heater with antifreeze medium (e.g.: glycol solution). In case of cutting off inflow of heating medium or operational standstill of the AHU and if air temperature may drop below + 5°C, the heater should be emptied.

In order to do so, please:

- close the valves at the heating agent's inflow and outflow (cut the heater off from the heating system)
- move the inspection panel towards the safety valves
- unscrew the drain and the vent plug from collectors
- connect the outflow hose to the drain to let the water go out of the drained exchanger outside the AHU
- blow through the heater with compressed air connected to the vent
- repeat this procedure several times at short intervals until only air goes out of the drain hose without any visible drops of water
- screw the drain and vent plugs back

Check contamination level of heater's lamellas at least every four months. Dust deposition on

If the final pressure difference exceeds designed value, it must be replaced.

During filter replacement also clean the filtration section - vacuum or dry cleaning.

In case of ordering a new filter set at the VTS authorized service provider, provide filter type, filtration class, AHU size and, if needed, size and number of filters according to the following table.

The AHUs always have to operate with installed air filters, otherwise fans power consumption may exceed designed values, which may lead to damage of the motor's wiring.

the heater surface deteriorates the heater's heating power and lead to pressure drop on the air side. Even if the AHU is equipped with filters, with time from the air supply side, dust settles onto the heater's lamellas. In case of contamination, cleaning should be carried out in one of the following ways:

- with a vacuum cleaner with soft suction nozzle from the air inlet side,
- by blowing through with compressed air in a direction opposite to normal air flow direction, directing air stream in parallel to the lamellas,
- washing with warm water with cleaning agents which do not cause aluminum or copper corrosion.

Before starting washing protect neighboring AHU sections against discharged dirt.

In order to achieve max. heating output of the heater, it must be well vented. Venting plugs are designed to do so and they are placed on heater's collectors.

During the AHU standstill, flow of the heating medium should be reduced to minimum so as temperature inside the AHU does not exceed + 60°C. Exceeding this value may lead to damage of some elements or subassemblies (motor, bearings, plastic elements, etc.) installed in the neighboring sections.

8.3.2. Electric Heater

Electric heater's battery consists of bare heating coils. During AHU operation, when the heater does not work, dust may settle onto the heating coils. Once the heater is turned on again, strong contamination may cause smell of burning dust or even preliminary fire danger may appear. Check regularly (every 4 months) and especially before starting a heating period, any electric connections, condition of heating elements and their contamination level. Any possible

8.3.3. Water cooler

Contamination level of the cooler should be checked each four months. If necessary, the cooler can be cleaned applying methods of cleaning the water heater.

Before starting washing protect neighboring AHU sections against discharged dirt.

While checking contamination level, check the condenser status as well as passability of water siphon. The water siphon should be filled

8.3.4. Freon cooler and heater

Maintenance of freon cooler covers the same range as the water heater and cooler. While washing the freon cooler with warm water, the cooling system should be emptied by sucking

8.3.5. Rotary exchanger

Inspection and maintenance of the drive belt of the energy recovery wheel must be carried out at the following intervals:

-12 hours after the new unit installation

-1 week after the installation

-after that, at least every 3 months

During maintenance activities of the rotary exchanger check if:

- rotor rotates freely. Sensible resistance can be caused by too excessive hold down of sealing brushes and touching the rotor's edges. In such a situation adjust the brushes properly. Worn out brushes sealing should be replaced. If previously removed brush sealing is to be installed again, it should be installed so that its direction should be in line with the rotor's rotation direction. After replacement or adjustment of sealing brushes, the exchanger should operate 30 minutes so that the brushes could adapt to the rotor's surface.

contamination should be removed with a vacuum cleaner with soft suction nozzle or with compressed air.

⚠ CAUTION! Wet cleaning of electric heater is forbidden!

Also check operation of overheating protection in case of lack of air-flow. Air speed should not be lower than 1.5 m/s.

with water before starting up the AHU. If the condenser is contaminated it should be washed with warm water with some cleaning medium.

In case of glycol cooler check level and density of glycol in the system. In order to achieve max. output of the cooler, it must be well vented. Venting plugs are designed to do so and they are placed on cooler's collectors.

off freon to the container. Otherwise there is a risk of uncontrolled increase of freon pressure and damage of the cooling system.

After this time check the motor's current and compare it with the rated current in order to find out if the motor is not overloaded.

- drive belt is not damaged and if it is clean as well as if it does not slip on the cylindrical part of the rotor. If despite maximal tension by the strain system the clearance still exists, the belt should be replaced or shortened,

- air inlet holes are not covered with dust or contaminated in any other way. In order to clean the rotor apply one of the methods designed for other exchangers.

Rolling bearings of rotor and drive motor are greased in continuous manner during operation. Amount of grease in bearings during the exchanger assembly is enough for long-lasting operation and there is no need to lubricate the bearings during operation. It is recommended to clean the motor and gear from dust so as an insulation layer was not formed on the motor's surface which may lead to increase of drive operating temperature.

8.3.6. Counter flow heat exchanger

Check the exchanger every four months and inspect its technical condition as well as contamination level. Dirt accumulation in plate heat exchangers is often limited to the first 50mm in the exchanger. Before starting washing protect neighboring AHU sections against discharged dirt.

Necessary cleaning should be carried out using:

- vacuum cleaning with soft suction nozzle,
- blowing through the ducts with air stream in a direction opposite to the normal air flow

8.4. Silencer section

Suppression section is equipped with slotted lever filled with non-flammable mineral wool absorbing acoustic energy. Maintenance procedures entail checking contamination level of suppression inserts. If cleaning is necessary the slotted levers can be removed one after another through the section inspection holes, previously removing screws fastening the

- direction,
- washing the air ducts at their whole length with water with cleaning agents which do not cause aluminum corrosion,
- in case of very contaminated exchangers you can use stream of compressed water to clean them.

While cleaning the exchanger using mechanical cleaning agents pay utmost attention not to damage or deform the exchanger's panels.

During exchanger operation in below zero temperature, the exchanger must be thoroughly dried before next start–up

8.5. Fan unit

Before starting any kind of works (failure, maintenance, servicing) with AHU, especially in case opening the inspection panels of fan section as well as removing cover plates under the drive, please make sure if:

- the device has been properly disconnected from power supply. It applies to both main and secondary circuits,

levers to the bottom and top. Re-assembly of the slotted levers in the section should be carried out in reverse order.

Leaning should be performed with a vacuum cleaner or wet wiping of all surfaces. In case of more serious contamination you can use nylon brushes.

8.5.1. Fans

Before starting any kind of works (failure, maintenance, servicing) with AHU, especially in case opening the inspection panels of fan section as well as removing cover plates under the drive, please make sure if:

- the device has been properly disconnected from power supply. It applies to both main and secondary circuits,
- rotor is not rotating,
- fan is cold and the surface temperate is safe,
- the fan is protected against unintended start–up.

- rotor is not rotating,
- fan is cold and the surface temperate is safe,
- the fan is protected against unintended start-up.

Fans are designed for transferring dust–free of light–dusted air. They are not designed for aggressive gases, steams or heavy–dusted air. Operating the fan in not suitable environment

can lead to damage of bearings, corrosion, unbalanced rotor or vibrations.

The fan and motor in the unit are designed for particular requirements and operation characteristics. Fan rotation speed is adapted so as the air stream and complete fan stress concentration were appropriate for a given ventilation system. Smaller stream of forced air results in disturbances in correct operation and leads to loss of balance of the entire ventilation system. It can be caused by:

- dust settlings on the fan's rotor blades,
- incorrect direction of fan's rotations. If the centrifugal fan rotates in incorrect direction, the air flow is carried out with significantly deteriorated output.
- In case of fan maintenance activities check if:

VTS reserves the right to implement changes without prior notice

- the rotor rotates freely,– the rotor is well balanced,
- the rotor is firmly mounted on pivot,
- did not change a location against the inlet cone,
- all screws fastening construction elements of the fan unit are tight.
- Lack of rotor's balance can be caused by:
 - dust settlings on the rotor's blades,
 - detachment of additional balancing weights,
 - damage of the rotor's blades.

Checking the contamination level of the casing inside, rotor and motor should be carried out every four months and the following elements should be cleaned:

- casing inside with a vacuum cleaner,
- rotor with a vacuum cleaner or by wet wiping with soft cleaning agent.

9. Safety instructions

- Connection and start-up of the AHU should be carried out by qualified personnel in accordance with recommended and designed regulations and guidelines regarding operation of electric devices.
- In no circumstances you are allowed to connect the device to power supply before connecting the protection system.
- In no circumstances you are allowed to carry out repairs or maintenance works if the device is connected to power supply.
- Operation of the AHU with removed inspection panel is strictly forbidden.
- Personnel operating, repairing or providing maintenance services on the AHU must be qualified and authorized to carry out these activities in line with regulations being in charge in a country where the AHU is assembled.
- AHU assembly location must be equipped with necessary safety and fire protection equipment in line with local regulations.



10. Information

Routine inspections carried out by qualified technical personnel or by VTS Authorized Service Providers guarantee long-term, reliable and failure-free operation of the device. Our service personnel is always available to accompany you during the start-up, maintenance and in case of any other emergency related to the device operation.

VTS Authorized Service Providers sell spare parts and accessories for our AHUs. While ordering parts please provide the AHU type and size as well as its serial number.

You can find more info regarding the network of VTS service providers at www.vtsgroup.com

11. Technical information to the regulation (U) No 327/2011 Implementing directive 2009/125/EC

Model:	225/0,75 EC	25/0,75 EC
1.	67,1%	67,3%
2.		
3.	Static	
4.	62	
5.	VSD - yes. A variable speed drive must be installed with this fan.	
6.	
7.	VTS, Poland	
8.	1-2-0294-2181	1-2-0294-2183
9.	750W, 1670m ³ /h, 1140Pa	750W, 1950m ³ /h, 1000Pa
10.	4500RPM	3800RPM
11.	1	
12.	<p>Disassembly of the machine must be carried out and/or supervised by qualified personnel with appropriate expert knowledge. Contact a certified waste disposal organization in your vicinity. Clarify what is expected in terms of the quality of dismantling the machine and provision of the components. Dismantle the machine using the general procedures commonly used in mechanical engineering.</p> <p>WARNING Machine parts can fall The machine is made up of heavy parts. These parts are liable to fall during dismantling. This can result in death, serious injury, or material damage. Follow the safety rules: 1. Disconnect all electrical connections. 2. Prevent reconnection. 3. Make sure that the equipment is at zero voltage. 4. Cover or isolate nearby components that are still live. To energize the system, apply the measures in reverse order.</p> <p>Components: The machines consist for the most part of steel and various proportions of copper, aluminum and plastics (impeller made of SAN - styrene, acrylonitrile, construction material with 20% glass fiber). Metals are generally considered to be unlimitedly recyclable. Sort the components for recycling according to whether they are: Iron and steel, aluminum, non-ferrous metal, e.g. windings (the winding insulation is incinerated during copper recycling), insulating materials, cables and wires, electronic waste, plastic parts (impeller, winding cover ect.). The same goes for cloths and cleaning substances which have been used while working on the machine. Dispose of the separated components according to local regulations or via a specialist disposal company.</p>	
13.	<p>Long failure-free operation depends on keeping the product/device/fan within performance limitations described by selection software or maintenance manual. For proper operation, read carefully maintenance manual, with special attention on "installation", "start-up", and "maintenance" chapters.</p>	
14.	no additional elements	