

# SPECIFICATION FOR VTS EC DRIVES

<b>1. PRODUCT DESCRIPTION</b>	<b>2</b>
<b>2. GENERAL REQUIREMENTS</b>	<b>2</b>
2.1 VERSIONS	2
2.2 EFFICIENCY LEVEL	2
<b>3. QUICK INSTALLATION INSTRUCTIONS</b>	<b>3</b>
3.1 STRIPPING CONNECTING LEADS AND CONNECTING WITH TERMINALS	3
3.2 CONNECTING THE ELECTRICAL SYSTEM	4
3.3 MAINS SUPPLY CONNECTION AND FUSE PROTECTION	4
➤ 170 W VERSION	4
➤ 370 W VERSION	5
➤ 750 W VERSION	5
<b>4. TECHNICAL REQUIREMENTS</b>	<b>7</b>
4.1 DRIVE TYPES	7
4.2 VOLTAGE	7
4.3 CLASS OF PROTECTION	7
4.4 MOUNTING STANDARD	7
4.5 TEMPERATURE CLASS	7
4.6 LIFE TIME	7
4.7 AMBIENT TEMPERATURE	7
4.8 HUMIDITY	7
4.9 COMMUNICATION OPTIONS	7
➤ 170 W VERSION	7
➤ 370 W VERSION	7
➤ 750 W VERSION	7
4.10 FUNCTIONS	7
4.11 PROTECTIONS	9
<b>5. COMPLIANCE WITH STANDARDS AND REGULATORS</b>	<b>10</b>
<b>6. CORRESPONDING STANDARDS</b>	<b>10</b>
<b>7. COMMUNICATION</b>	<b>11</b>
7.1 MODBUS RTU	11
7.2 MODBUS PARAMETERS	12
➤ COILS	12
➤ DISCRETE INPUTS	12
➤ HOLDING REGISTERS	13
➤ INPUT REGISTERS	14
<b>8. TROUBLESHOOTING</b>	<b>15</b>
<b>9. CONNECT WITH VTS AUTOMATIC</b>	<b>16</b>

## 1. PRODUCT DESCRIPTION

Product is EC drive for different VTS ventilation units. The drive consists of electronic and EC motor. Electronic is integrated on the back side of the motor – it is fixed on the motor with 3 screws. Only listed requirements for the drive can be fulfilled and delivered to VTS. Below is the picture of the drive.

- Electronic description: Electronic is potted into electronic holder approximately 5 mm high – to cover the pins of the electronic components. With this measure electronic is protected from drop water. Power supply connectors and motor connectors are protected from drop water with electronic cover. Connectors with screw connection for wires are used. After potting process electronic is screwed to the motor. Cover of the motor protects also power elements from drop water. Electronic holder and electronic cover are made from black PA66 plastic material.
- Motor description: Front end shield A made from aluminum. Stator with winding overmoulded together with back end shield B with BMC plastic. Shaft with slot for key and central thread in front.

Version 1

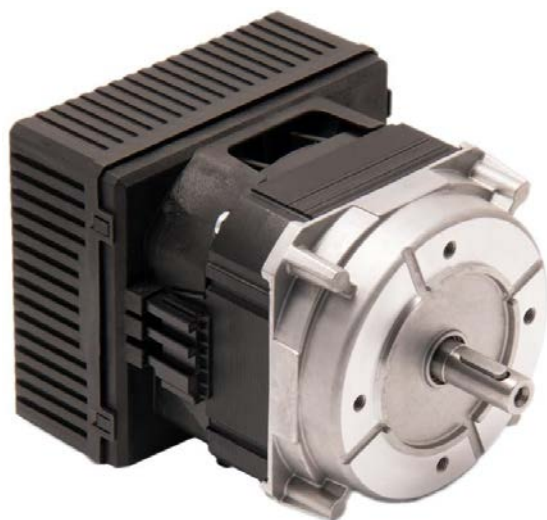

Version 2

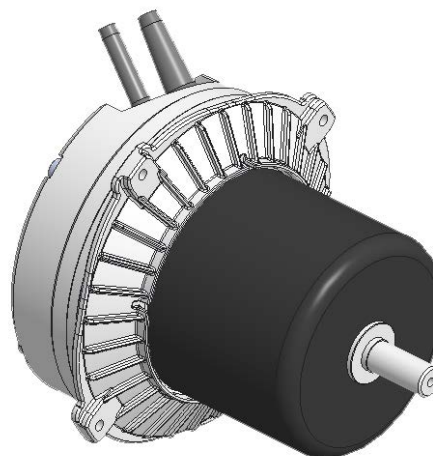

## 2. GENERAL REQUIREMENTS

### 2.1 VERSIONS

From the motor side we have 3 different lengths of the motors: with stator stack length 26 mm, 30 mm and 35 mm. From the controller side 2 different electronic versions are used: 170W, 370W and 750W version. Combination of stator stack length, electronic version and winding configuration give the possibility to create drive type adapted to different operational conditions and products.

Drives are primarily used in following VTS products: air handling units, water heaters and air curtains. They can also be used in other VTS products.

EC motors come in different power versions, while for the standardization two regulators are used, with a powers of 370W (for motor up to 400W) and 750W (for motor up to 860W).

### 2.2 EFFICIENCY LEVEL

The drives must have at least efficiency level IE4 according to IEC 60034-30 standard.

### 3. QUICK INSTALLATION INSTRUCTIONS



**Danger!**  
Electric voltage on the device

EC-Drive could connect, install, modify or repair only expert person! Incorrect mounting could cause material damage and risk of fatal injury from electric shock! VTS is not responsible for any damage, which could be made by no expert mounting, wrong and bad circuit connection!

Use fuses at power lines. Install all earth wires. Before operating, check the wires for short circuits. Use only cables that meet the specified installation requirements for voltage, current, insulation material, load etc.



**Warning!**  
Electric voltage!

Never upon into EC-Controller or parts of them when the main supply is connecting. It can be extremely dangerous!

To protect the touch with high voltage, disconnect main supply voltage and wait at least 5 minutes



**Note!**

It is the responsibility of the user or installer to ensure correct grounding and protection in accordance with national and local standards.

### 3.1 STRIPPING CONNECTING LEADS AND CONNECTING WITH TERMINALS

Use only hard wire or fiber copper wire with ferrule (Fig 1). For thickness of the wire, see the table 2.

For reduce the operating problems, use a shield cable. Max length of cables shown the table below.

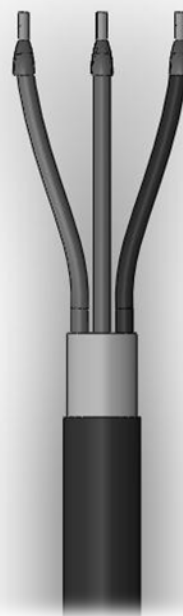

Fig.1: Wire with ferrule

	170W	370W	750W
	Length max [m]		
Power supply	-	-	-
Set RPM via voltage	-	-	-
Set RPM via potentiometer	-	-	20
Speed Out	-	-	-
Start/Stop	-	-	40
Modbus	40	40	40

### Connection instructions:

1. Remove the Top cover of the terminal strips
2. Screw control and main power cables to the connector.



#### Warning!

Be careful with cable connection, use schema on page 4 (370W) or page 5 (750W) to insure proper cable connection to proper pin on connector. Wrong connection could cause fatal damage on the controller and other devices connected to the controller. Damaged terminal strips could cause fatal damage on the Controller and could cause fatal injury from electric shock.

3. Check all connections again and carefully replace the Top cover.
4. Connect the Power supply voltage.



#### Note!

It is the responsibility of the user or installer to ensure correct grounding and protection in accordance with national and local standards.

### 3.2 CONNECTING THE ELECTRICAL SYSTEM

Check whether the data on the type plate agree with the connection data.

Before connecting the device, ensure that the supply voltage matches the operating voltage of the device.

Only use cables that are configured for current according to the specification on the type plate.

### 3.3 MAINS SUPPLY CONNECTION AND FUSE PROTECTION

	Drive type	Nominal voltage	Nominal input power	Safety fuse	Cable cross - section	
					mm <sup>2</sup>	AWG
Power supply	E04	230V	170W	2A	1,0 - 1,5	18
	E04	230V	370W	4A	2,0 - 2,5	13
	E04	230V	750W	6,3A	2,0 - 2,5	13
User control			-		0,5 - 2,5	20 - 13

Table 2: Thickness of wire



#### Note!

Connect the device only to the circuits that can be switched off using an all pole disconnecting switch.

#### ➤ 170 W VERSION

	Cable color	Description
Control	A	White Bus connection RS485 - A; MODBUS RTU
	B	Yellow Bus connection RS485 - B; MODBUS RTU
Main Supply	PE	Yellow/Green PE connection
	L	Brown Supply voltage
	N	Blue 220 - 240V AC

The 170W version of the motor is supplied with a cable and factory connectors:

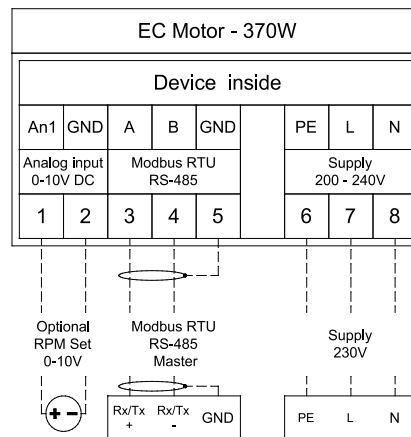
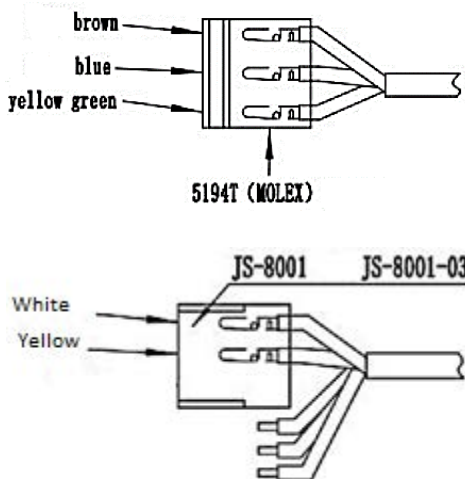

➤ **370 W VERSION 1**

	Terminal number	Description
Control	AN	1 Analog Input; Set value 0-10 V DC; $R \geq 1 \text{ k}\Omega$
	GND	2, 5 I/O ground
	A	3 Bus connection RS485 - A; MODBUS RTU
	B	4 Bus connection RS485 - B; MODBUS RTU
Main Supply	PE	6 PE connection
	L	7 Supply voltage
	N	8 220V – 240V AC

➤ **750 W VERSION 1**

Terminal number	Description
-----------------	-------------

Control	AN	1	Analog Input; Set value 0-10 V DC; $R \geq 1 \text{ k}\Omega$
	GND	2, 6, 12	I/O ground
	Pot	3	Potentiometer output (3 wires)
	+5V	4	+5 V $\pm$ 5 % / 10 mA for potentiometer
	Speed*	5	Digital output; Speed Output PWM signal; $f \sim 1.1 \text{ kHz}$ ; NPN open collector output
	I/O*	7	Option for additional input/output function
	+5V	8	+5 V $\pm$ 5 % / 10 mA for switch and I/O function
	Start / Stop	9	Digital input; Disabling function - open pin; <b>Enabling Bridge to +5 V (Pin 9 to Pin 8)</b>
	A	10	Bus connection RS485 - A; MODBUS RTU
	B	11	Bus connection RS485 - A; MODBUS RTU
Mains Supply	PE	13	PE connection
	L	14	Supply voltage 220 – 240V AC
	N	15	

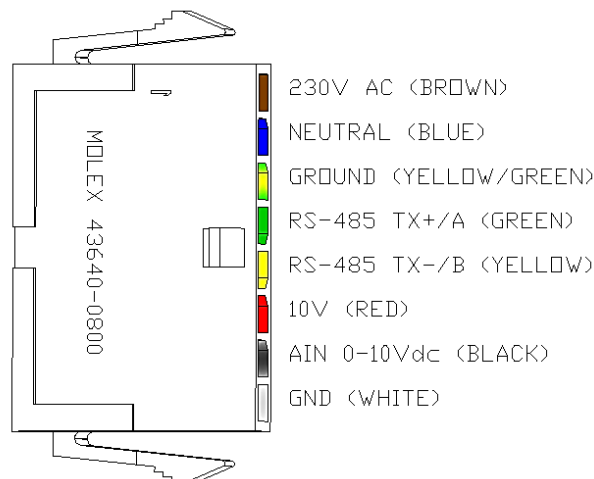
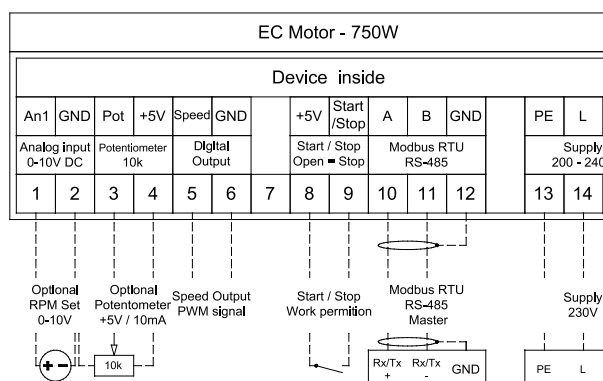

➤ **370/750 W VERSION 2**

	Terminal Number / color	Description
Main Supply	L 1 Brown	Supply voltage 220 – 240V AC
	N 2 Blue	
	PE 3 Yellow/Green	PE connection
Control	A 4 Green	Bus connection RS485 - A; MODBUS RTU
	B 5 Yellow	Bus connection RS485 - B; MODBUS RTU
	10V 6 Red	Output 10V DC
	AIN 7 Black	Analog Input; Set value 0-10 V DC; R ≥ 1 kΩ
	GND 8 White	I/O ground

## 4. TECHNICAL REQUIREMENTS

### 4.1 DRIVE TYPES

Status of different drive types on May 2017.

Fan Type	Motor nominal speed (RPM)	Motor max. output power (W)	Torque max. (Nm)	Controller Type - power (kW)
Axial 444 Cross flow WING 200	1.400	300	2,05	0,37 (230V)
Axial 420	1.340	205	1,46	0,37 (230V)
Axial 315	1.400	80	0,55	0,37 (230V)
Cross flow WING 100 WING 150	1.340	205	1,46	0,37 (230V)
Plug 190	4.500	170	1,25	0,18 (230V)
Plug 225	3.600	349	1,00	0,37 (230V)
Plug 225	4.500	735	1,56	0,75 (230V)
Plug 250	3.000	349	1,1	0,37 (230V)
Plug 250	3.800	700	1,76	0,75 (230V)
Plug 315	2.060	374	1,72	0,37 (230V)
Plug 315	2.600	715	2,64	0,75 (230V)

### 4.2 VOLTAGE

Nominal voltage: 1 x 230 V , ± 10%

Nominal frequency: 50 / 60 Hz

### 4.3 CLASS OF PROTECTION

IP44 (IP20) according to EN 60529 standard / dependent of version.

### 4.4 MOUNTING STANDARD

Flange mounting – version B14.

### 4.5 TEMPERATURE CLASS

Temperature insulation class: F.

### 4.6 LIFE TIME

Demanded life time:

- 70.000 hours at 70% maximal load and temperature 35 °C
- 30.000 hours at 100% maximal load and temperature 55 °C

### 4.7 AMBIENT TEMPERATURE

Ambient temperature: from -25°C to 55°C.

### 4.8 HUMIDITY

Relative humidity: from 0% to 40%; (from 5% to 95% - without condensation).

### 4.9 COMMUNICATION OPTIONS

#### ➤ 170 W VERSION

- MODBUS - addressing of the drives (up to 32 pcs.) via software, adjustable: 9600, 19200 and 38400

#### ➤ 370 W VERSION 1

- MODBUS - addressing of the drives (up to 32 pcs.) via software, adjustable baud rate: 9600, 19200 and 38400
- 0 – 10 V input

#### ➤ 750 W VERSION 1

- MODBUS - addressing of the drives (up to 32 pcs.) via software, adjustable baud rate: 9600, 19200 and 38400
- 0 – 10 V input
- Potentiometer input
- Speed output

#### ➤ 370 / 750 W VERSION 2

- MODBUS - addressing of the drives (up to 32 pcs.) via software, adjustable baud rate: 9600, 19200 and 38400
- 0 – 10 V input

### 4.10 FUNCTIONS

#### Analog input only for 370W and 750W.

**AN1:** Analogue input 1 – Electronics can be controlled by external analogue input voltage 10-0 VDC to terminals (1 and 2). Electronics controls speed linear from RPM min to RPM max. Maximal or minimal speed is defined as input voltage 9,5V ± 3%.

To start control the motor speed by AN1, in 750W version connect Stop/Start terminal pins (8 and 9) together. AN1 can be settable by

holding registers 107, 108 and 109 (see Modbus parameters in chapter 7). AN1Min parameter can be be set to the desired minimum setpoint. AN1Max parameter can be set to the desired maximum setpoint. AN1Min and AN1Max can be set from 0V to 10V. If AN1Max is smaller than AN1Min function is inverted (10V to 0V). By AN1Stop, stop threshold voltage can be set. If AN1Stop is 0 threshold voltage is disabled and motor will run with minimal settable RPM. By setting AN1Stop higher than 0 motor will not run up to settable value.

and motor will run with minimal RPM also in case of AN1 and POT is 0V. In picture 2 AN1stop is set to 1V. This means that threshold voltage is 1 and motor will not run below 1V.

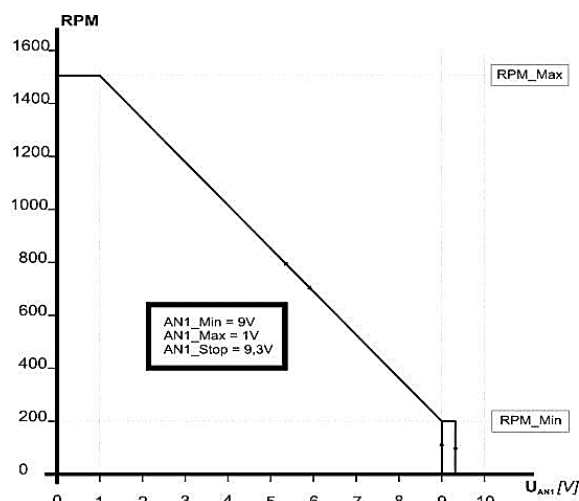
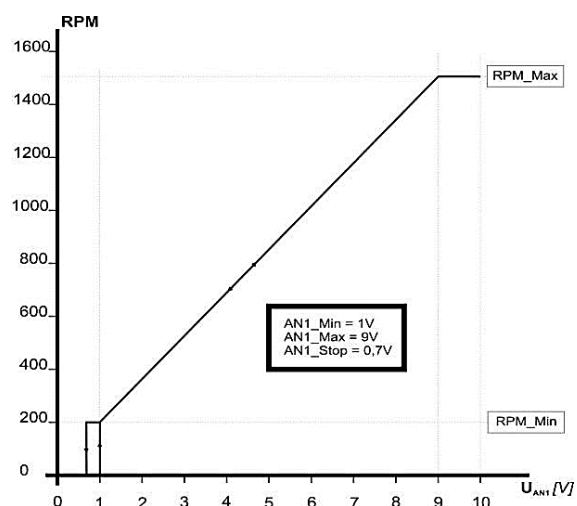
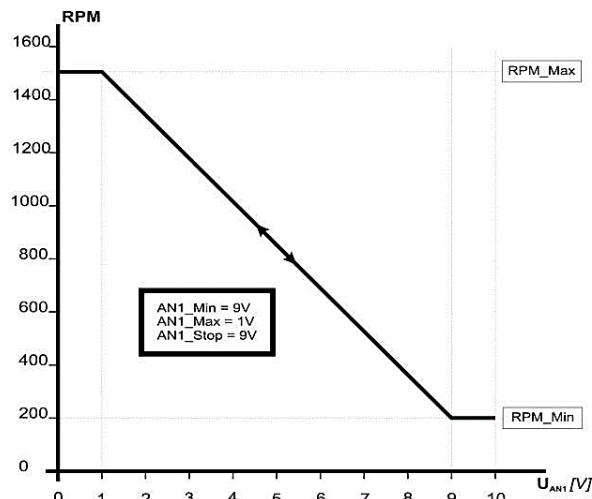
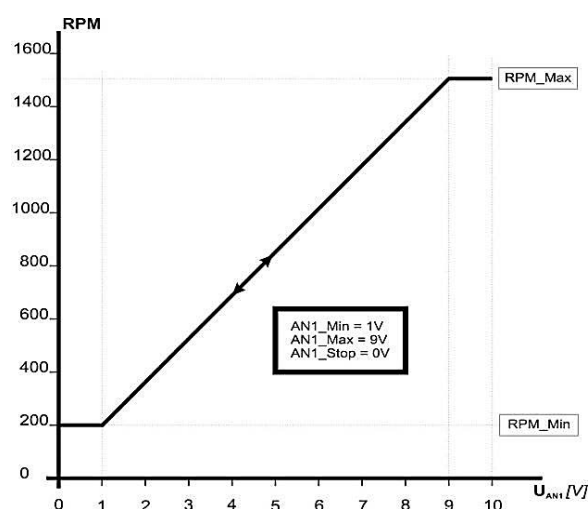

AN1min is set to 1V and AN1max is set to 9V. In the pictures above, controller works from 200RPM to 1500RPM. AN1 operates from 1V to 9V (AN1max > AN1min). AN1stop is set to 0V in picture 1, this means that AN1stop is disabled

AN1min is set to 9V and AN1max is set to 1V. In the pictures above, controller works from 200RPM to 1500RPM and AN1 operates inverted from 9V to 0V (AN1max < AN1min).

AN1stop is set to 10V in picture 3, this means that AN1stop is disabled and motor will run with minimal RPM also in case of AN1 and POT is 10V. In picture 2 AN1stop is set to 9V. This means that threshold voltage is 9V and motor will not run higher than 9V.

Electrical parameters: Vin<sub>max</sub>=12V, Zin=10kΩ, Resolution 10-bit, tolerance AN1±5%.



**Important: Wrong polarity at input AN1 could cause serious damage on the controller.**

**Modbus RTU 485 serial communication:**  
 Electronics are equipped with Modbus RTU 485 communication. To connect controllers into chain use only shielded cables.

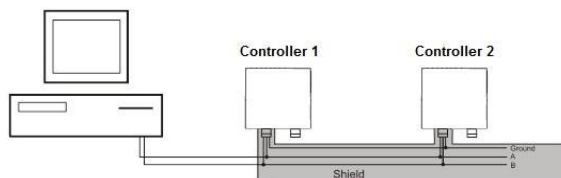

Shielded cable for ground connection between controllers is necessary (version 350W terminal pin 5, version 750W terminal pin 12).

#### Speed control via MODBUS:

Parameter "Operation Mode" set to value 2 - Operation Mode = 2. To the Holding register at address 0 (Set\_Point) write desired value of speed in %.

For example:

Set\_Point < 1000 (10,00 %) ... Motor Stop

Set\_Point = 1000 (10,00 %) ... Motor Run at RPM\_Min

1000 (10,00 %) < Set\_Point <= 10000

(100,00 %) ... Motor Runs at desired speed.

The motor speed is calculated by equation:

$$Speed[RPM] = RPM_{Min} + \frac{RPM_{Max} - RPM_{Min}}{9000} * Set\_Point[\%]$$

**For additional information about Modbus parameters see chapter 7.**

## 4.11 PROTECTIONS

**Thermal protection:** The electronics are equipped with reducing thermal protection. This function is a temperature limiter which reduces the output power, when temperature on the controller rises over 90°C.

In the event that the temperature of controller is still rising (over 105°C) the controller stops the motor. When the temperature controller falls below 75°C, the motor automatically restarts.

**Under and over voltage:** The electronics are equipped with under and over voltage protection. Electronics shutdown when the main voltage is not in the required range. See mechanical and electrical specification.

**Blocked rotor protection:** The electronics are equipped with blocked rotor protection when the rotor of motor is blocked or it is impossible to rotate it. Electronics automatically retries 25 restarts, than a manual restart by disconnecting the power supply is required.

**Motor phase fail / lose:** The electronics are equipped with motor phase fail protection in event that one of phase motors is damage or missing. In this case electronics stops the motor immediately.

**Phase overcurrent protection:** The electronics are equipped with phase overcurrent protection. In this event electronics stops the motor immediately and tries to makes automatically restart.

**Rotor failed acceleration:** The electronics are equipped with rotor failed acceleration protection when the rotor is damaged or is hard to rotate. Electronics automatically retries 25 restarts for every 1second. If the 25<sup>th</sup> restart is still unsuccessful, then manual restart by disconnecting the power supply is required.



#### **Note!**

**Heating the controller over the maximal temperature is not allowed.**

**Above 105°C electronics stops the motor, and restarts it again when the temperature of controller falls below 75°C. However, if the controller is overheating and motor was shutdown, disconnect power supply (safety switch) and wait at least 20 minutes before you service them. In case of overheating of controller, the metal parts of them are very hot and could cause serious damage to your skin.**

**If controller starts reducing output power during running, this may be reason of overheating. Ensure air flow through the ribs/motor. Overheating problem appears in the case of installation of the controller in the space without air flow.**

## 5. COMPLIANCE WITH STANDARDS AND REGULATORS

### ➤ 170 W VERSION

- Regulators: CE, ROHS, REACH
- Compliance regarding EMC: class A (industrial environment)

### ➤ 370 W VERSION

- Regulators: CE, ROHS, REACH
- Compliance regarding EMC: class A (industrial environment)
- Compliance regarding harmonics: passive PFC with PFC choke on the PCB  
*Passive PFC choke on PCB NOT to meet harmonics according to EN 61000-3-2; passive PFC choke is needed to increase power factor and therefore life time of the controller!*

### ➤ 750 W VERSION

- Regulators: UL, CSA, CE, ROHS, REACH
- Compliance regarding EMC: class B (industrial and residential environment)
- Compliance regarding harmonics: passive PFC with PFC choke on the PCB

## 6. CORRESPONDING STANDARDS

Following standards should be considered:

### ➤ 170 W VERSION

Standard	Standard description
EN 61000-3-2	Electromagnetic compatibility (EMC) – Part 3-2: Limits – Limits for Harmonic current emissions
EN 61000-3-3	Electromagnetic compatibility (EMC) – Part 3-3: Limits = Limitation of voltage changes, voltage fluctuations
EN 61000-6-2	Electromagnetic compatibility (EMC) – Part 6-2: Generic standards Immunity for industrial environments
EN 61000-6-3	Electromagnetic compatibility (EMC) – Part 6-3: Generic standards – Emission standard

### ➤ 370 W VERSION

Standard	Standard description
EN 61000-6-4	Electromagnetic compatibility (EMC) –

	Part 6-4: Generic standards - Emission standard for industrial environments
EN 61000-6-2	Electromagnetic compatibility (EMC) – Part 6-2: Generic standards - Immunity for industrial environments
EN 61000-4-2	Electromagnetic compatibility (EMC) – Part 4-2: Testing and measurement techniques - Electrostatic discharge immunity test
EN 61000-4-3	Electromagnetic compatibility (EMC) – Part 4-3: Testing and measurement techniques - Radiated, radio-frequency electromagnetic field immunity test
EN 61000-4-4	Electromagnetic compatibility (EMC) – Part 4-4: Testing and measurement techniques - Electrical fast transient/burst immunity test
EN 61000-4-5	Electromagnetic compatibility (EMC) – Part 4-5: Testing and measurement techniques - Surge immunity test
EN 61000-4-6	Electromagnetic compatibility (EMC) – Part 4-6: Testing and measurement techniques - Immunity to conducted disturbances, induced by radio-frequency fields
EN 61000-4-8	Electromagnetic compatibility (EMC) – Part 4-8: Testing and measurement Techniques - Power frequency magnetic field immunity test
EN 61000-4-11	Electromagnetic compatibility (EMC) – Part 4-11: Testing and measurement techniques - voltage dips, short interruptions and voltage variations

### ➤ 750 W VERSION

Standard	Standard description
EN 50178	Electronic equipment for use in power installations
EN 61000-6-4	Electromagnetic compatibility (EMC) – Part 6-4: Generic standards - Emission standard for industrial environments
EN55011	Industrial, scientific and medical equipment (ISM) - Radio-frequency disturbance characteristics - limits and methods of measurements
EN 61000-6-2	Electromagnetic compatibility (EMC) – Part 6-2: Generic standards - Immunity for industrial environments
EN 61000-4-2	Electromagnetic compatibility (EMC) – Part 4-2: Testing and measurement techniques - Electrostatic discharge immunity test
EN 61000-4-3	Electromagnetic compatibility (EMC) – Part 4-3: Testing and measurement techniques - Radiated, radio-frequency electromagnetic field immunity test
EN 61000-4-4	Electromagnetic compatibility (EMC) – Part 4-4: Testing and measurement techniques - Electrical fast transient/burst immunity test
EN 61000-4-5	Electromagnetic compatibility (EMC) – Part 4-5: Testing and measurement techniques - Surge immunity test

EN 61000-4-6	Electromagnetic compatibility (EMC) – Part 4-6: Testing and measurement techniques - Immunity to conducted disturbances, induced by radio-frequency fields
EN 61000-4-8	Electromagnetic compatibility (EMC) – Part 4-8: Testing and measurement Techniques - Power frequency magnetic field immunity test
EN 61000-4-11	Electromagnetic compatibility (EMC) – Part 4-11: Testing and measurement techniques - voltage dips, short interruptions and voltage variations
EN 61000-3-2	Electromagnetic compatibility (EMC) – Part 3-2 - Limits for harmonic current emissions (equipment input current <= 16 A per phase)
EN61000-3-3	Electromagnetic compatibility (EMC) - Part 3-3: Limits - Limitation of voltage changes, voltage fluctuations and flicker in public low-voltage supply systems, for equipment with rated current <= 16 A per phase

connected to the signal TX+, RX+, while terminal 4 for 350W or terminal 11 for 750W is connected to the signal TX-,RX-.

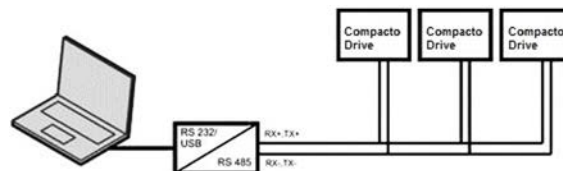

Parallel connections

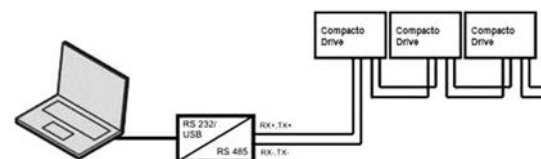

“Daisy chain” connection

Default Configuration (set by VTS):

- MODBUS address: **1 for Fan, 4 for RRG**
- Baud Rate: **9600**
- START Bit: **1**
- STOP Bit: **1**
- Parity: **NONE**

Supported MODBUS commands:

- 0x01: Read Coils
- 0x02: Read Input
- 0x03: Read Holding Registers
- 0x04: Read Input Register
- 0x05: Write Single Coil
- 0x06: Write Single Holding Register

To connect PC and VTS Drive over serial line (MODBUS) RS-232/USB to RS-485 Converter is needed.

#### Recommended signal converters:

To ensure proper communication between the PC and EC motors and other devices with ModBUS communication, it is recommended to use converters based on the FTDI chipset. Additionally, as needed, more advanced versions of such RS485-USB converters can be equipped with surges protection, which ensures safety when working in an industrial environment.

## 7. COMMUNICATION

### 7.1 MODBUS RTU

The MODBUS RTU protocol is based on the built-in RS-485 (EIA-485) interface. RS-485 is a two-wire bus-interface that allows multi-drop network topology i.e. nodes can be connected as a bus (daisy chain), or via drop cables from a common trunk line.

VTS drives uses the two-wire system where the communication between master and slave is halfduplex, i.e. it cannot transmit and receive at the same time. Each signal uses one twisted-pair line — two wires twisted around themselves. The signal on one wire is ideally the exact opposite of the signal on the second wire. Since RS-485 is a multipoint communication system, all devices are connected to the single twisted-pair cable.

The Modbus RTU uses master/slave architecture, where each slave device has its unique address and responds only to packets addressed to this device. The packets are generated by the master (Controller), which periodically polls all connected slave devices. Data travels over the single line in both directions.

One or more EC drives can be connected to a control (or master) using the RS-485 standardized interface. Maximal number of Compacto EC Drives connected to the network is 32. If more than one frequency converter is connected to a master, use parallel connections. Terminal 3 for 350W or terminal 10 for 750W is

## 7.2 MODBUS PARAMETERS

Configuration
MODBUS RTU: 9600-8-N-1
Slave addr: 0x1 (default settable by MB_ADR:0007)
(Strikethrough text indicates partially implemented or unimplemented function)



### Note!

ACCESS LEVEL:  
 0 – Read only  
 1 – Basic user settings  
 2 – Service settings

### ➤ COILS

Coils (read / write)			
Address	Function	Range	Description
0	Motor ON/OFF	0-1	Indication, 1=ON, 0=OFF
1	Reset Controller	0-1	1=Reset controller

### ➤ DISCRETE INPUTS

Discrete status bits (read only)			
Address	Function	Range	Description
0	Under Voltage	0-1	1=Voltage too low to run
1	Over Voltage	0-1	1=Voltage too high to run
2	IGBT Overcurrent	0-1	1=Overcurrent protection tripped
3	Hot	0-1	1=Temperature protection active, power reduced
4	Phase Loss	0-1	1=Phase or motor sync loss
5	RESERVED		
6	Parameters CRC	0-1	1=Parameter checksum failed (TBD)
7	Circuit Fault	0-1	1=There was an error detected during circuit internal check
8	Motor Fault	0-1	1=Motor does not behave as expected
9	Too Hot	0-1	1=Converter too hot to operate
10	I2R IGBT Fault	0-1	1=Software IGBT protection triggered
11 - 13	RESERVED		
14	Restart Fault	0-1	1=Fault condition repeated several times in a short time. Converter power should be power cycled or reset.
15	RESERVED		
16 - 17	RESERVED		
18	Waiting To Stop	0-1	1=Motor should be stopped, but is still spinning
19 - 23	RESERVED		
24	RpmReg	0-1	Speed regulator active
25	PowerReg	0-1	Power limit regulator active
26	RESERVED		
27	OvermodReg	0-1	Over modulation reached. Converter can no longer supply the voltage required by motor.
28	RegenReg	0-1	Motor is in regeneration. Speed increased to prevent DC link over voltage
29	IphaseReg	0-1	RMS motor phase current limit reached
30	SyncReg	0-1	Motor is still in Synchronous mode
31	RESERVED		

➤ **HOLDING REGISTERS**

Holding Registers (read / write)					
Address	Function	Range	Resolution	Description	LEVEL
0	Set point	0 ... 10000	0,01%	Performance set point for speed depends on operation mode.	1
1	Direction	0 ... 65535	1	Motor direction: 0: clockwise rotation. >0: anti-clockwise rotation	2
2	Maximum Speed	MinRPM... MaxRPM[level+1]	1	Max rpm allowed in normal operation. External control will use this as set point maximum. Value from level above current is used as Max.	1
3	RESERVED				
4	MinRPM[level+1] ... MaxRPM	10% RPM to Max RPM	1	Minimal allowed speed	1
5	Password	0 ... 32767		<p><b>0:</b> level 0, all settings locked (default password for level 1)</p> <p><b>1:</b> password for current level will be disabled with 10020</p> <p><b>10000:</b> store values to EEPROM at current level (will override lower levels)</p> <p><b>10001:</b> restore values from EEPROM (last saved values)</p> <p><b>10002:</b> restore default values from one level above current</p> <p><b>10020:</b> set previous value as password (will not be accepted if desired password matches 10000..11000 or level is &lt;1)</p> <p><b>1234:</b> password for level 2</p> <p>See 1: for how to disable password 10003+0: Enter level 1 with default password When level is changed, stored values for the level will be loaded</p> <p><b>24681:</b> Password for level 2 in Version 2</p>	1
6	Operation Mode			0: AN1 Speed (default) 2: MODBUS Speed	1
7	Modbus Address	1 ... 247	1	Set Modbus address: Write 10000 to Password to save. Restore by writing to broadcast address (0) (in case you forgot address)	1
8	MODBUS connection detection	0/1	1	Detection MODBUS connection loos. 1: MODBUS disconnection ignored, 0: MODBUS disconnection used for motor stop	
9 -17	RESERVED				
18	Modbus speed	1 - 3	1	Modbus speed can be changed: 1: baud rate <b>9600 (default)</b> , 2: baud rate 19200, 3: baud rate 38400. Notice: after baud rate change Modbus communication will not work, also change baud rate on converter to get proper working.	1
Load configuration					
20 - 31	FACTORY SETTINGS				
Controller configuration – Version 1					
100 - 106	RESERVED				
107	AN1Max	0 ... 1000	0.01V	Voltage for maximum setpoint. Transfer function is inverted if AN1Max < AN1Min.	1

108	AN1Min	0 ... 1000	0.01V	Voltage for minimum setpoint	1
109	AN1Stop	0 ... 1000	0.01V	0: disable stop - AN1Stop > 0: Stop threshold voltage.	1
Controller configuration – Version 2					
11	AN1Max	0 ... 1000	0.01V	Voltage for maximum setpoint. Transfer function is inverted if AN1Max < AN1Min.	1
12	AN1Min	0 ... 1000	0.01V	Voltage for minimum setpoint	1
13	AN1Stop	0 ... 1000	0.01V	0: disable stop - AN1Stop > 0: Stop threshold voltage.	1

## ➤ INPUT REGISTERS

Input Registers (read only)				
Address	Function	Range	Resolution	Description
0	HW Version		1	Hardware version
1	FW Version		1	Firmware version
2..3	RESERVED			
4	Speed	0 ... 32767	1	RPM
5	Controller temperature	-50 ... 150	0.01	°C
6	UDC		0.1	DC Bus voltage in V
7	Stator IRMS		0.001	RMS Stator current in A
8	Power		0.1	W
9	Analogue1	-300 ... 2000	0.01V	Analogue input 1 voltage
10 - 18	RESERVED			
19	Error Code	0 ... 7, -1		Red LED error codes (priority in the order below): 0 = always on (operating normally) -1 = fast blink (fire activated) 1 = slow blink = standby 2 = active overcurrent protection 3 = temperature protection active 4 = internal frequency converter fault 5 = motor misconnected/faulty 6 = under or overvoltage 7 = motor failed to start repeatedly
20 - 21	RESERVED			
23	Op Minutes			Minutes of operation
24	Op Days			Days of operation (RPM>0, no error)

## 8. TROUBLESHOOTING

The power supply must be disconnected for at least 5 minutes before the EC controller is opened. Otherwise the unit may contain residual current capable of causing serious injury.

COMPACTO	Errors/Warnings	Modbus Error Warning	Restart Required Manual Restart *	Restart Required Auto Restart	Limits/Remarks
1	AC input undervoltage	X		X	230 V: $60\text{ V} < \text{UAC} < 150\text{ V}$
2	AC input overvoltage	X		X	230 V: $\text{UAC} > 265\text{ V}$
3	Blocked rotor	X	X		Manual restart required after 25 automatically restarts
4	Failed rotor acceleration	X		X	Auto restart after 1s; After 25 automatically restarts, manual restart required
5	Phase failure/phase loss	X	X		Phase damage/missing motor phase
6	Overheating windings	X			No overheating windings protection
7	Overheating electronics	X			Temp. Electronics $< 90\text{ }^{\circ}\text{C}$ . Reducing output power
		X		X	Temp. Electronics $< 105\text{ }^{\circ}\text{C}$ . Motor shutdown: Decreasing Temp. Of electronics below $75\text{ }^{\circ}\text{C}$ . Automatically restart
8	Controller error (internal error of electronics)	X	X		
9	Phase overcurrent	X	X		Motor phase current $> 4\text{ A}$
		X	X		Contact motor phase to phase or phase to earth (PE)
10	Motor fault	X		X	Something is wrong with motor or fans parts
11	Run active	X			Indicator
12	Waiting to stop	X			Indicator - Tells when motor stop

\* Disconnect controller from Power distribution network for 5 min.

## 9. CONNECT WITH VTS AUTOMATIC

